

**PATIENT PACKAGE INSERT IN ACCORDANCE WITH THE PHARMACISTS'
REGULATIONS (PREPARATIONS) – 1986**

The medicine is dispensed with a doctor's prescription only

Trusopt Eye drops

Active ingredient:

Dorzolamide (as hydrochloride) 20 mg/ml

For the list of the additional ingredients, see section 6. See also 'Important information about some of the medicine's ingredients' in section 2.

Read this entire leaflet carefully before using the medicine.

This leaflet contains concise information about the medicine. If you have any further questions, please refer to your doctor or pharmacist.

This medicine has been prescribed to treat your illness. Do not pass it on to others. It may harm them, even if it seems to you that their illness is similar to yours.

1. What is the medicine intended for?

The medicine is intended for lowering raised pressure in the eye and for treating glaucoma.

Therapeutic Group: carbonic anhydrase inhibitors.

2. Before using the medicine

Do not use the medicine if:

- You are sensitive (allergic) to the active ingredient or to any of the additional ingredients the medicine contains (for the list of the additional ingredients, see section 6).
- If you have a severe impairment of kidney function or kidney problems, or if you have a history of kidney stones.

Special warnings regarding the use of this medicine:

Before (and during) treatment with the medicine, tell your doctor if:

- You suffer or have suffered in the past from any medical problem, including eye problems and/or eye surgeries.
- You suffer from any allergy to medicines.
- You suffer or have suffered in the past from liver problems.
- You suffer or have suffered in the past from impaired kidney function - see also the "Do not use the medicine if" section.

Additional warnings

- If you are sensitive to any food or medicine, including sulfonamide-derived medicines, inform your doctor before using this medicine.
- If while using the medicine an eye allergic reaction, eye irritation or any other new eye problems such as redness of the eye or swelling of the eyelids appear, contact the doctor immediately.
- If you think that the medicine is causing you any allergic reaction (for example, skin rash, severe skin reaction or itching), stop using the medicine and contact the doctor immediately.
- If you think that the medicine has become contaminated, or if you develop an eye infection, contact the doctor immediately about continuing use of the bottle. See also section 3.

Children and adolescents: there is no information on the safety and effectiveness of use of this medicine in children and adolescents.

Drug interactions:

If you are taking, or have recently taken any other medicines, including non-prescription medicines and nutritional supplements, please tell your doctor or pharmacist. Especially

inform your doctor or pharmacist if you are taking the following medicines (it should be noted that the following list indicates the active ingredients in the medicines. If you are not sure whether you are using one of these medicines please consult with your doctor or pharmacist):

- Other eye drops.
- Other medicines from the carbonic anhydrase inhibitor group such as acetazolamide.
- Medicines containing sulfa.

Pregnancy and breastfeeding:

If you are pregnant, think you are pregnant, are planning a pregnancy or are breastfeeding, consult your doctor before using the medicine.

- **Pregnancy:** Do not use this medicine during pregnancy. Tell your doctor if you are pregnant or are planning a pregnancy. There is insufficient information on the use of this medicine during pregnancy.
- **Breastfeeding:** It is not known whether the medicine passes into the breastmilk. If treatment with this medicine is required, breastfeeding is not recommended. Tell your doctor if you are breastfeeding or if you are planning to breastfeed.

Driving and use of machinery:

There are side effects associated with use of the medicine, such as dizziness and blurred vision, which may affect your ability to drive and/or operate machinery. Do not drive or operate machinery until you feel well and/or your vision reverts to being clear.

Important information about some of the medicine's ingredients:

This medicine contains 0.075 mg/ml benzalkonium chloride (preservative), while each drop contains approximately 0.002 mg benzalkonium chloride.

Benzalkonium chloride may be absorbed by soft contact lenses and may change the color of the contact lenses. If you wear contact lenses, remove the lenses before using the medicine and wait at least 15 minutes before putting them back.

Benzalkonium chloride may cause eye irritation, especially if you have dry eyes or disorders of the cornea. If you feel an abnormal eye sensation, stinging or pain after using the drops, refer to your doctor.

3. How to use this medicine?

Always use the medicine according to the doctor's instructions. Check with your doctor or pharmacist if you are not sure about the dosage and the manner of treatment with the medicine.

The dosage, manner of treatment and duration of treatment will be determined by the doctor only.

This medicine is indicated for use in the eyes. Do not swallow!

The standard dosage is usually: one drop in the treated eye(s) 3 times daily.

If you use Trusopt with other eye drops or with another product for local treatment of the eye, ensure a gap of at least 10 minutes between them.

Do not exceed the recommended dosage.

Use this medicine at set times as determined by the attending doctor.

Do not allow the tip of the bottle to come into direct contact with your fingers, eyes or with the areas around the eyes, to prevent infection (which may lead to serious damage of the eye and even loss of vision).

In addition, you must wash your hands before using the medicine and prevent the tip of the bottle from coming into contact with any surface. Close the bottle tightly.

If you think that the medicine has become contaminated, or if you develop an eye infection, refer to your doctor immediately about continuing use of the bottle.

Manner of use

Before use of the medicine

Before using the medicine for the first time, check that the safety strip on the front of the bottle is unbroken. A gap between the bottle and the cap is normal for an unopened bottle (**See Fig. A**).

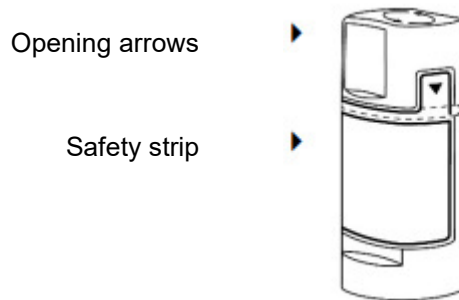

Fig. A

Step 1. Wash your hands thoroughly before use.

Step 2. Tear off the safety strip (seal) to break the seal. **See Fig. B.**

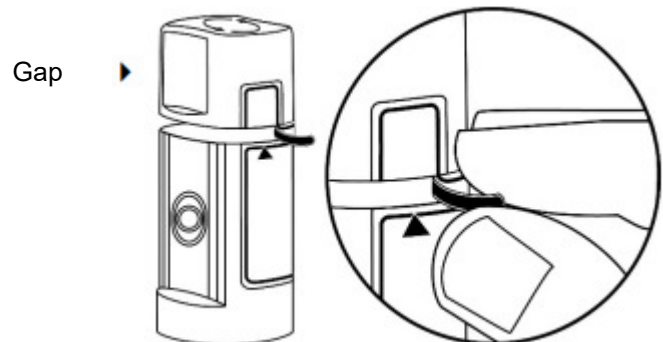

Fig. B

Step 3. To open the bottle, turn the cap in the direction of the arrows marked on the top part of the cap. **Do not pull** the cap straight up from the bottle. Pulling the cap in this way could impair the normal function of the bottle. **See Fig. C.**

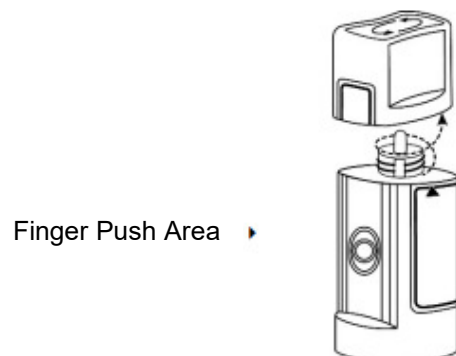

Fig. C

Dispensing the drops

Step 4. Tilt your head back and slightly distance your lower eyelid from the eye to form a pocket between your eyelid and the eye. **See Fig. D.**



Fig. D

Step 5. Turn the bottle upside down and press lightly with the thumb or index finger on the “Finger Push Area” until one drop is dispensed into the eye. **Do not touch the eye or eyelid with the dispenser tip. See Fig. E.**



Fig. E

Step 6. If the drop was not released easily from the bottle, after it was first opened, put the cap back on the bottle and tighten it. **Do not screw it too tight.** Remove the cap by turning it in the direction of the arrows marked on its top part. **See Fig F.** This action should enlarge the hole of the dispenser tip. **Do not** try to enlarge the hole of the dispenser tip in any other way. The dispenser tip is designed to provide one measured drop.

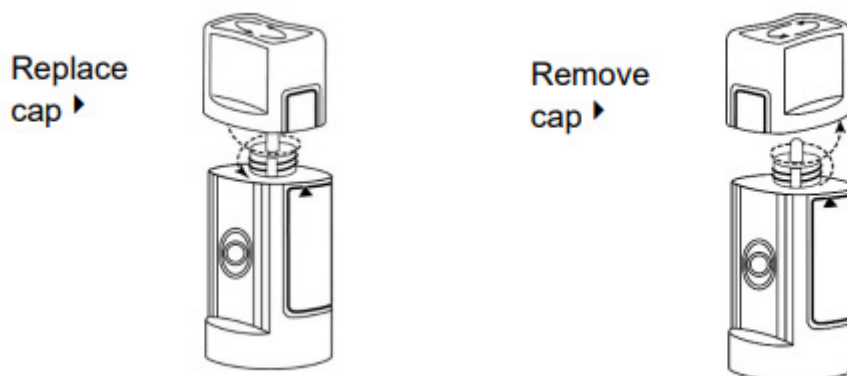

Fig. F

Step 7. Repeat steps 4 & 5 in the second eye if those were the doctor’s instructions.

After use of the medicine

Step 8. Replace the cap by turning it until it is firmly touching the bottle. **Pay attention** not to overtighten the cap, since this might damage the bottle and the cap. **See Fig. G.**

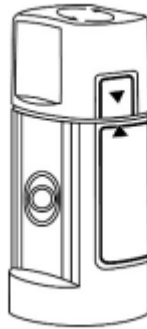

Fig. G

After you have used all the doses, there may be a little solution left in the bottle. You should not be concerned since the bottle contains an extra amount of solution so that you will get the full amount of the medicine as per the doctor's instructions. Do not attempt to remove the excess amount of the solution from the bottle.

If you have accidentally used a higher dosage: if you put too many drops in your eye or if somebody has accidentally swallowed the medicine, proceed immediately to the doctor and bring the medicine package with you.

Overdose symptoms can include drowsiness (if the drops are swallowed), nausea, dizziness, headache, fatigue, unusual dreams, impaired swallowing.

If you forgot to take the medicine: It is important to use the medicine as prescribed by the doctor. If you forgot to instill a dose at the set time, instill it as soon as possible, but if it is almost time for the next dose, skip the forgotten dose, and continue use according to the regular schedule. Do not use a double dose to compensate for the forgotten dose.

Adhere to the treatment as recommended by your doctor. Even if your state of health improves, do not stop the treatment with this medicine without consulting your doctor.

Do not take medicines in the dark! Check the label and the dose each time you take a medicine. Wear glasses if you need them.

If you have further questions concerning the use of the medicine, consult your doctor or pharmacist.

4. Side effects

As for any medicine, the use of Trusopt may cause side effects in some users. Do not be alarmed while reading the list of side effects. You may not suffer from any of them.

Stop treatment and seek immediate medical assistance if the following side effects appear:

- If you develop an allergic reaction including hives (urticaria), swelling of the face, lips, tongue, and/or throat which may cause breathing or swallowing difficulties.

Additional side effects (including frequencies):

Very common side effects (appear in more than 1 user out of 10):

Burning and stinging of the eyes.

Common side effects (appear in 1-10 users out of 100):

Disease of the cornea with sore eye and blurred vision (superficial punctate keratitis), secretion with itching of the eyes (conjunctivitis), tearing, irritation/inflammation of the eyelids, itching in the eye, blurred vision, headache, nausea, bitter taste, fatigue/weakness.

Uncommon side effects (appear in 1-10 users out of 1,000):

Inflammation of the iris.

Rare side effects (appear in 1-10 users out of 10,000):

Tingling or numbness in the hands or feet, temporary shortsightedness which may resolve when treatment is stopped, accumulation of fluid under the retina (choroidal detachment, following filtration surgery), eye pain, eyelid crusting, low eye pressure, edema/swelling of the cornea (with symptoms of visual disturbances), eye irritation including redness, kidney stones, dizziness, nose bleed, throat irritation, dry mouth, localized skin rash (contact dermatitis), severe skin reactions (Stevens-Johnson syndrome, toxic epidermal necrolysis), allergic reactions such as rash, hives (urticaria), itching, in rare cases possible swelling of the lips, eyes and mouth, shortness of breath, and more rarely wheezing.

Side effects of unknown frequency (effects whose frequency has not yet been determined):

Shortness of breath, foreign body sensation in eye (feeling that there is something in the eye), forceful heartbeat that may be rapid or irregular (palpitations), increased heart rate and high blood pressure.

If a side effect appears, if one of the side effects worsens, or if you suffer from a side effect not mentioned in the leaflet, consult with your doctor.

Side effects may be reported to the Ministry of Health by clicking on the link "Report on side effects following medicinal treatment" on the homepage of the Ministry of Health website (www.health.gov.il) which leads to an online form for reporting side effects, or by entering the link: <https://sideeffects.health.gov.il/>

5. How to store the medicine?

- Avoid poisoning! This medicine, and any other medicine, must be stored in a closed place out of the reach and sight of children and/or infants, to avoid poisoning. Do not induce vomiting unless explicitly instructed to do so by the doctor.
- Do not use the medicine after the expiry date (exp. date) stated on the package. The expiry date refers to the last day of that month.
- Storage conditions: store below 30°C. Protect from light.
Do not use this medicine for more than 1 month after the bottle is first opened and no later than the expiry date stated on the package.

6. Additional information

In addition to the active ingredient, the medicine also contains:

Mannitol, Hydroxyethylcellulose, Sodium citrate, Benzalkonium chloride, Sodium hydroxide, Water for injection.

What does the medicine look like and what does the package contain?

Clear, colorless or nearly colorless, slightly viscous solution in plastic 5 mL bottle.

Manufacturer: Fareva Mirabel, Clermont-Ferrand, France

Registration holder: Rafa Laboratories Ltd., P.O. Box 405, Jerusalem 9100301

Medicine registration number in the National Medicines Registry of the Ministry of Health:
106-58-28935-00

Revised in March 2023 according to MOH's guidelines.

177003-FM