

**PATIENT LEAFLET IN ACCORDANCE WITH THE PHARMACISTS' REGULATIONS
(PREPARATIONS) - 1986**

The medicine is dispensed with a doctor's prescription only

Signifor® LAR 10 mg, powder and solvent for suspension for injection

The active ingredient and its quantity:

Each vial of powder contains: 10 mg pasireotide (as pamoate)

Signifor® LAR 20 mg, powder and solvent for suspension for injection

The active ingredient and its quantity:

Each vial of powder contains: 20 mg pasireotide (as pamoate)

Signifor® LAR 30 mg, powder and solvent for suspension for injection

The active ingredient and its quantity:

Each vial of powder contains: 30 mg pasireotide (as pamoate)

Signifor® LAR 40 mg, powder and solvent for suspension for injection

The active ingredient and its quantity:

Each vial of powder contains: 40 mg pasireotide (as pamoate)

Signifor® LAR 60 mg, powder and solvent for suspension for injection

The active ingredient and its quantity:

Each vial of powder contains: 60 mg pasireotide (as pamoate)

Inactive and allergenic ingredients: see section 6 'Additional information' and section 2 'Important information about some of this medicine's ingredients'.

Read the entire leaflet carefully before you start using this medicine. This leaflet contains concise information about this medicine. If you have further questions, refer to the doctor or pharmacist.

This medicine has been prescribed to treat your illness. Do not pass it on to others. It may harm them, even if it seems to you that their illness is similar to yours.

1. WHAT IS THIS MEDICINE INTENDED FOR?

Signifor LAR is indicated for the treatment of adult patients with acromegaly for whom surgery is not an option or has not been curative and who are inadequately controlled on treatment with other somatostatin analogues.

It is also indicated for treatment of Cushing's disease in adult patients for whom surgical treatment is not an option or for whom surgery has failed.

10 mg and 30 mg strengths are intended for treatment of Cushing's disease only.

60 mg strength is intended for treatment of acromegaly only.

Therapeutic group: Pituitary and hypothalamic hormones and analogues, somatostatin analogues.

Acromegaly

Acromegaly is caused by a type of tumour called a pituitary adenoma, which develops in the pituitary gland at the base of the brain. The adenoma leads the body to over-produce hormones that control growth of tissues, organs and bones, resulting in an increase in the size of bones and tissues, especially in the palms of the hands and soles of the feet. Signifor LAR reduces the production of these hormones and possibly also the size of the adenoma. As a result, it reduces the symptoms of acromegaly, which include headache, increased sweating, numbness in the palms of the hands and soles of the feet, tiredness and joint pain.

Cushing's disease

Cushing's disease is caused by an enlargement in the pituitary gland (a gland at the base of the brain) called a pituitary adenoma. This leads the body to overproduce a hormone called adrenocorticotrophic hormone (ACTH), which in turn results in overproduction of another hormone called cortisol.

The human body naturally produces a substance called somatostatin, which blocks the production of certain hormones, including ACTH. Pasireotide works in a very similar way to somatostatin. Signifor LAR is thus able to block the production of ACTH, helping to control the overproduction of cortisol and improve the symptoms of Cushing's disease.

2. BEFORE USING THIS MEDICINE

X Do not use this medicine if:

- | |
|--|
| <ul style="list-style-type: none">• you are sensitive (allergic) to pasireotide or to any of the additional ingredients contained in the medicine (listed in section 6).• you have severe liver problems. |
|--|

! Special warnings about using this medicine

Before treatment with Signifor LAR, tell your doctor if you currently have or have ever had:

- problems with your blood sugar levels, whether the levels are too high (as in hyperglycaemia/diabetes) or too low (hypoglycaemia);
- heart problems such as a recent heart attack, heart failure (a type of heart disease where the heart cannot pump enough blood around the body), or sudden and oppressive chest pain (usually felt as pressure, heaviness, tightening, squeezing or aching across the chest);
- a heart rhythm disorder, such as an irregular or too low heartbeat, or an abnormal electrical signal called "prolongation of the QT interval" or "QT prolongation";
- low levels of potassium or magnesium in the blood;
- gallstones;
- or if you are taking anticoagulants (medicines used to reduce the clotting ability of the blood). The doctor will monitor the coagulation parameters and may adjust your anticoagulant dose.

During treatment with Signifor LAR:

- Signifor LAR controls over-production of cortisol. The control may be too strong and you may experience signs or symptoms associated with a lack of cortisol, such as extreme weakness, tiredness, weight loss, nausea, vomiting or low blood pressure. If this happens, tell your doctor immediately.

Children and adolescents

Do not give this medicine to children and adolescents below 18 years of age. There is no information on the safety and efficacy of use of this preparation in children and adolescents.

Tests and follow-up

- Signifor LAR may cause your blood sugar level to increase. The doctor may want to monitor your blood sugar levels and start treatment with or adjust your anti-diabetic medicine.
- Signifor LAR may lower the heart rate. Your doctor may wish to monitor the heart rate using a machine that measures electrical activity of the heart (an “ECG”, or electrocardiogram). If you are using a medicine to treat heart problems, the doctor may also need to adjust its dosage.
- The doctor may wish to check your gallbladder, liver enzymes and pituitary hormones periodically, since these might all be affected by the medicine.

Drug interactions

If you are taking, or have recently taken other medicines, including nonprescription medicines and dietary supplements, tell the doctor or pharmacist.

Signifor LAR may affect the way some other medicines work. If you are taking other medicines at the same time as Signifor LAR (including non-prescription medicines), your doctor may need to monitor your heart activity more carefully or change the dose of Signifor LAR or the other medicines.

In particular, inform the doctor if you are taking any of the following medicines:

- medicines used in organ transplantation to reduce the activity of the immune system (ciclosporin);
- medicines used to treat blood sugar levels that are too high (as in diabetes) or too low (hypoglycaemia), such as:
 - insulin;
 - metformin, liraglutide, vildagliptin, nateglinide (anti-diabetic medicines);
- medicines used to treat irregular heartbeat, such as medicines containing disopyramide, procainamide, quinidine, sotalol, dofetilide, ibutilide, amiodarone or dronedarone;
- medicines to treat bacterial infections (given by mouth: clarithromycin, moxifloxacin; given by injection: erythromycin, pentamidine);
- medicines to treat fungal infections (ketoconazole, except in shampoo);
- medicines to treat certain psychiatric disorders (chlorpromazine, thioridazine, fluphenazine, pimozide, haloperidol, tiapride, amisulpride, sertindole, methadone);
- medicines to treat hay fever and other allergies (terfenadine, astemizole, mizolastine);
- medicines for prevention or treatment of malaria (chloroquine, halofantrine, lumefantrine);
- medicines to control blood pressure such as:
 - beta blockers (metoprolol, carteolol, propranolol, sotalol);
 - calcium channel blockers (bepridil, verapamil, diltiazem);
 - cholinesterase inhibitors (rivastigmine, physostigmine);
- medicines to control the balance of electrolytes (potassium, magnesium) in your body;
- anticoagulants (medicines used to reduce the clotting ability of the blood).

Pregnancy, breast-feeding and fertility

Consult the doctor or pharmacist before using any medicine.

- You should not use Signifor LAR during pregnancy unless necessary. If you are pregnant, think you may be pregnant or are planning to become pregnant, consult with your doctor before taking this medicine.
- If you are breast-feeding, consult with your doctor before taking this medicine since it is not known if Signifor LAR passes into breast milk. Stop breast-feeding during treatment with Signifor LAR.

- If you are a sexually active woman, you should use an effective method of contraception during treatment. Ask your doctor about the need for contraception before taking the medicine.

Driving and using machines

Signifor LAR may have a minor effect on the ability to drive or operate machines, since some of the side effects you may experience while using Signifor LAR, such as headache, dizziness and tiredness, may reduce your ability to drive and operate machines safely.

Important information about some of the medicine's ingredients

Signifor LAR contains less than 1 mmol (23 mg) sodium per dose, so it is essentially considered 'sodium-free'.

3. HOW TO USE THIS MEDICINE?

This medicine will be given to you by a trained healthcare professional.

How much Signifor LAR should be used

Always use the medicine according to the doctor's instructions. Check with the doctor or pharmacist if you are not sure about your dose or about how to take this medicine. Only your doctor will determine your dose and how you should take this medicine.

Acromegaly

The recommended starting dose of Signifor LAR for the treatment of acromegaly is 40 mg every 4 weeks. After you have started treatment, the doctor may reassess the dose. This may include measuring the levels of growth hormone or other hormones in the blood. Depending on the results and how you are feeling, the dose given in each injection may need to be reduced or increased. The dose should not exceed 60 mg. If you had a liver disease before starting treatment with Signifor LAR for acromegaly, the doctor may want to start your treatment with a dose of 20 mg.

Cushing's disease

The usual starting dose of Signifor LAR for the treatment of Cushing's disease is 10 mg every 4 weeks. After you have started treatment, your doctor may reassess your dose. This may involve measuring the levels of cortisol in your blood or urine. Depending on the results and how you are feeling, the dose given in each injection may need to be reduced or increased. The dose should not exceed 40 mg.

The doctor will regularly check how you respond to the treatment with Signifor LAR and will determine which dose is best for you.

Do not exceed the recommended dose.

How to take Signifor LAR

The doctor or nurse will inject you with Signifor LAR. If you have any questions, contact the doctor, nurse or pharmacist.

Signifor LAR is intended for intramuscular use. This means that the preparation is injected through a needle into the muscles of the buttocks.

Duration of Signifor LAR treatment

This is a long-term treatment, possibly lasting for years. The doctor will regularly monitor your condition to check that the treatment is having the desired results. Continue treatment with Signifor LAR for as long as the doctor tells you to do so.

If you took an overdose or if a child has accidentally swallowed some medicine, immediately see a doctor or go to a hospital emergency room and bring the medicine package with you.

If you forget to take the medicine

If you forget to get a Signifor LAR injection, get one as soon as possible. Plan the next injection 4 weeks thereafter, to maintain a regular regimen of one injection every 4 weeks.

Adhere to the treatment regimen recommended by the doctor.

Even if there is an improvement in your health, do not stop treatment with the medicine without consulting the doctor.

If you stop taking the medicine

If you stop taking the medicine, your symptoms may return. Therefore, do not stop using Signifor LAR unless the doctor tells you to do so.

Do not take medicines in the dark! Check the label and the dose every time you take medicine. Wear glasses if you need them.

If you have further questions about using this medicine, consult the doctor, nurse or pharmacist.

4. SIDE EFFECTS

As with any medicine, use of Signifor LAR may cause side effects in some users. Do not be alarmed by this list of side effects. You may not suffer from any of them.

Some side effects can be serious. Tell the doctor immediately if you get any of the following effects:

Very common side effects (effects which appear in more than one in ten users):

- High levels of sugar in the blood. You may experience excessive thirst, high urine output, increased appetite accompanied by weight loss, tiredness, nausea, vomiting, abdominal pain.
- Gallstones or complications related to gallstones. You may experience fever, chills, yellowing of the skin/eyes, sudden back pain or pain in the right side of the abdomen.

Common side effects (effects which appear in 1-10 in 100 users):

- Low cortisol levels. You may experience extreme weakness, tiredness, weight loss, nausea, vomiting and low blood pressure.
- Slow heartbeat.
- Prolonged QT interval (an abnormal electrical signal in your heart that can be seen in tests).
- Problems with bile flow (cholestasis). You may experience yellowing of the skin, dark urine, pale stools and itching.
- Inflammation of the gallbladder (cholecystitis).

Additional side effects:

Very common side effects (effects which appear in more than one in ten users):

- Diarrhoea.
- Nausea.
- Abdominal pain.
- Fatigue.

Common side effects (effects which appear in 1-10 in 100 users):

- Tiredness, fatigue, pale skin (signs of a low level of red blood cells).
- Loss of appetite.
- Headache.
- Bloating.
- Vomiting.
- Dizziness.
- Pain, discomfort, pruritis and swelling at the injection site.
- Change in liver function test results.
- Abnormal blood test results (sign of high level of creatine phosphokinase, glycosylated haemoglobin, lipase in the blood).
- Hair loss.
- Itching.

Uncommon side effects (effects which appear in 1-10 in 1000 users):

- Change in pancreatic function blood test results (amylase).
- Abnormal blood clotting properties.

Side effects of unknown frequency (effects whose frequency has not been determined yet):

- Increased levels of ketone bodies (a group of substances produced in the liver) in the urine or blood (diabetic ketoacidosis), as a complication resulting from increased blood sugar levels. You may experience a fruity breath, breathing difficulty and confusion.

If a side effect occurs, if any side effect gets worse or if you experience a side effect not mentioned in this leaflet, consult your doctor.

Side effects can be reported to the Ministry of Health by clicking on the “Report Side Effects of Drug Treatment” link on the Ministry of Health home page (www.health.gov.il), which opens an online form for reporting side effects, or you can also use this link:

<https://sideeffects.health.gov.il>

5. HOW TO STORE THE MEDICINE?

- Prevent poisoning! To prevent poisoning, keep this and all other medicines in a closed place, out of the reach and sight of children and/or infants. Do not induce vomiting unless explicitly instructed to do so by your doctor.
- Do not use this medicine after the expiry date (exp. date) which is stated on the carton, the vial and the pre-filled syringe containing the solvent. The expiry date refers to the last day of that month.

Storage conditions

- Store in the refrigerator (2°C – 8°C). Do not freeze.
- Use the preparation immediately after reconstitution.
- Do not throw away any medicines via household waste or wastewater. Ask the pharmacist how to dispose of medicines which are no longer in use. These measures will help protect the environment.

6. ADDITIONAL INFORMATION

- **In addition to the active ingredient, the medicine also contains:**

In the powder:

poly(D,L-lactide-co-glycolide) (50-60:40-50), poly(D,L-lactide-co-glycolide) (50:50).

In the solvent:

mannitol, carmellose sodium/carboxymethylcellulose sodium, poloxamer 188, water for injections.

- **What the medicine looks like and the contents of the pack:**

Signifor LAR powder is slightly yellowish to yellowish in a vial. The solvent is clear, colourless to slightly yellow or slightly brown in a pre-filled syringe.

Each package contains one vial of powder and a pre-filled syringe containing the solvent in a sealed blister tray that also includes one vial adapter and one needle for injection.

- **Registration holder's name and address:** Medison Pharma Ltd., 10 Hashiloach St., Petach Tikva.
- **Manufacturer's name and address:** Recordati Rare Diseases, Puteaux, France.
- This leaflet was revised in October 2023 according to MOH guidelines.
- Registration numbers of the medicine in the National Drug Registry of the Ministry of Health:
 - Signifor LAR 10 mg: 172 50 36981
 - Signifor LAR 20 mg: 154 91 34334
 - Signifor LAR 30 mg: 172 51 36982
 - Signifor LAR 40 mg: 154 92 34340
 - Signifor LAR 60 mg: 154 93 34341

The following information is intended for healthcare professionals only:

INSTRUCTIONS FOR USE OF SIGNIFOR LAR POWDER AND SOLVENT FOR SUSPENSION FOR INJECTION

FOR DEEP INTRAMUSCULAR INJECTION ONLY.

ATTENTION:

There are two critical steps in the reconstitution of Signifor LAR. **Not following them could result in failure to deliver the injection appropriately.**

- **The injection kit must reach room temperature.** Remove the injection kit from the fridge and let the kit stand at room temperature for a minimum of 30 minutes before reconstitution, but do not exceed 24 hours.
- After adding the solvent, **shake the vial moderately** for a minimum of 30 seconds **until a uniform suspension is formed.**

Included in the injection kit:

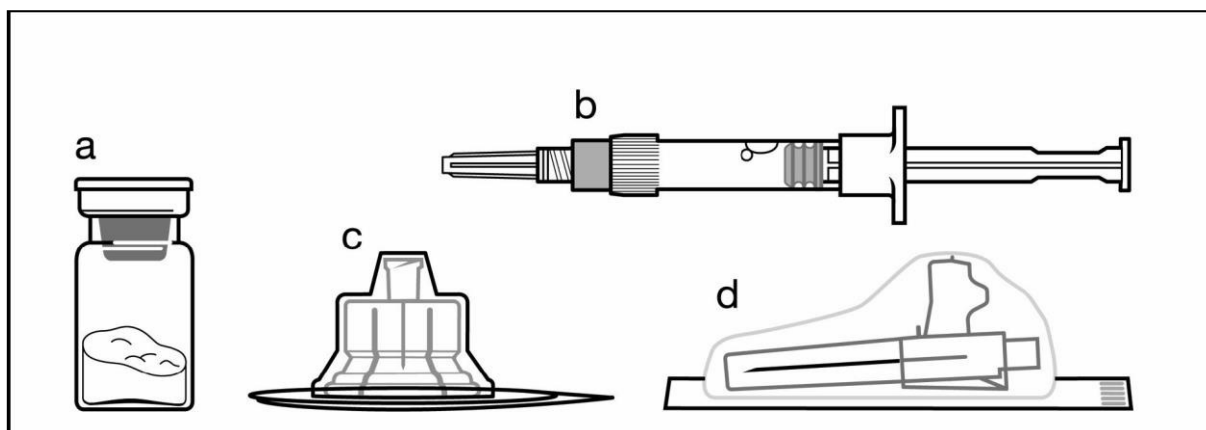

- a One vial containing the powder
- b One pre-filled syringe containing the solvent
- c One vial adapter for medicinal product reconstitution
- d One safety injection needle (20Gx1.5")

Follow the instructions below carefully to ensure proper reconstitution of Signifor LAR powder and solvent for suspension for injection before deep intramuscular injection.

Signifor LAR suspension must only be prepared immediately before administration. For further details please see Prescribing Information.

Signifor LAR should only be administered by a trained healthcare professional.

Signifor LAR 10 mg-20 mg-30 mg-40 mg-60 mg-PIL-1023-V1

Signifor LAR-10mg_20mg_30mg_40mg_60mg-PIL-ENG-D17-F

Step 1

Remove the Signifor LAR injection kit from refrigerated storage.

ATTENTION: It is essential to start the reconstitution process only after the injection kit reaches room temperature. Let the kit stand at room temperature for a minimum of 30 minutes before reconstitution, but do not exceed 24 hours.

Note: If not used within 24 hours, the injection kit can be returned to the fridge.



Step 2

Remove the plastic cap from the vial and clean the rubber stopper of the vial with an alcohol wipe.

Remove the lid film of the vial adapter packaging, but do NOT remove the vial adapter from its packaging.

Holding the vial adapter packaging, position the vial adapter on top of the vial and push it fully down so that it snaps in place, confirmed by a “click”.

Remove the packaging from the vial adapter by lifting it straight up as shown.



Step 3

Remove the cap from the syringe pre-filled with solvent and **screw** the syringe onto the vial adapter.

Slowly push the plunger all the way down to transfer all the solvent in the vial.

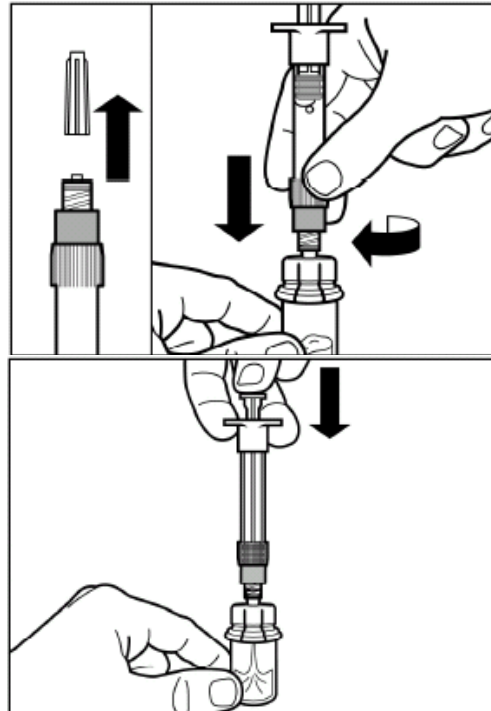

Step 4

ATTENTION: Keep the plunger pressed and shake the vial **moderately for a minimum of 30 seconds** so that the powder is completely suspended. **Repeat moderate shaking for another 30 seconds if the powder is not completely suspended.**

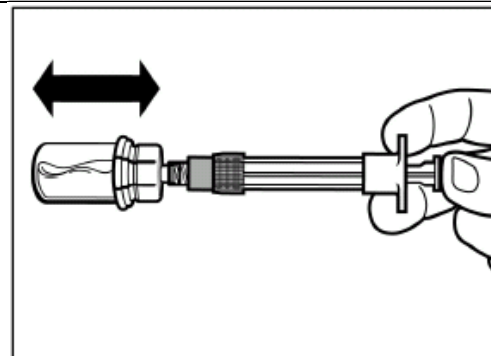

Step 5

Turn syringe and vial upside down, **slowly** pull the plunger back and draw the entire content from the vial into the syringe.

Unscrew the syringe from the vial adapter.

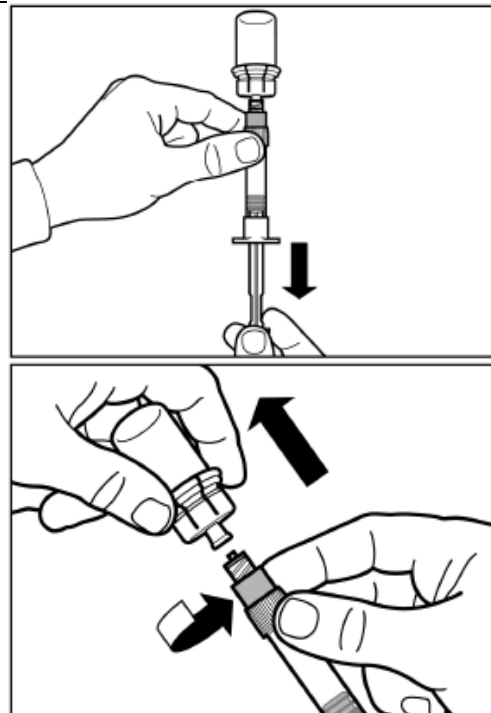

Step 6

Screw the safety injection needle onto the syringe.

Pull the protective cover straight off the needle. To avoid sedimentation, you may gently shake the syringe to maintain a uniform suspension. Gently tap the syringe to remove any visible bubbles and expel them from the syringe. The reconstituted Signifor LAR is now ready for **immediate** administration.

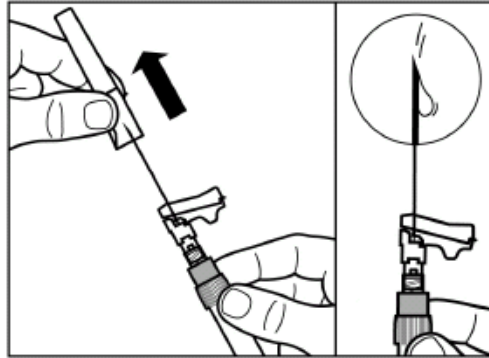
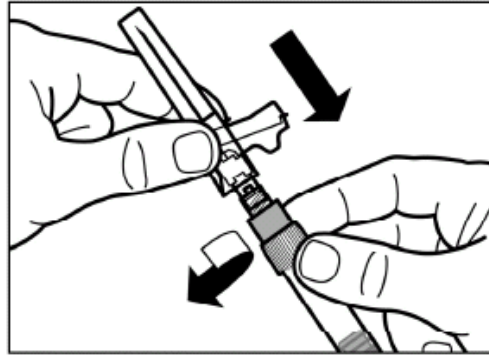

Step 7

Signifor LAR must be given only by deep intramuscular injection.

Prepare the injection site with an alcohol wipe.

Insert the needle fully into the left or right gluteus at a 90° angle to the skin.

Slowly pull back the plunger to check that no blood vessel has been penetrated (reposition if a blood vessel has been penetrated).

Slowly depress the plunger until the syringe is empty. Withdraw the needle from the injection site and activate the safety guard (as shown in Step 8).

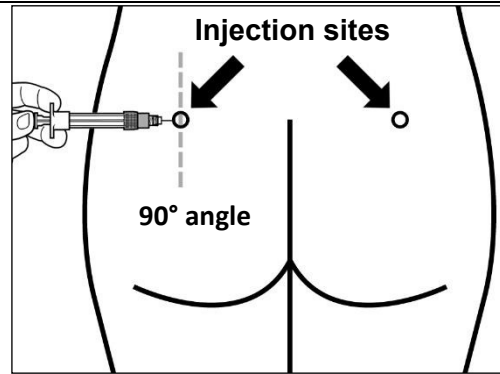
**Step 8**

Activate the safety guard over the needle, in one of the two methods shown:

- either press the hinged section of the safety guard down onto a hard surface (figure A),
- or push the hinge forward with your finger (figure B).

An audible “click” confirms proper activation.

Dispose of syringe immediately in a sharps container.

