

**PATIENT PACKAGE INSERT IN ACCORDANCE WITH THE PHARMACISTS' REGULATIONS (PREPARATIONS) – 1986**

The medicine is dispensed with a doctor's prescription only

## Dupixent 300 mg

### Solution for injection in a pre-filled syringe with needle shield

**Active ingredient:**

Each pre-filled syringe of Dupixent 300 mg contains 300 mg dupilumab.

Inactive and allergenic ingredients in the preparation: see section 2 and section 6.

**Read this leaflet carefully in its entirety before using the medicine.**

Keep this leaflet; you may need to read it again. This leaflet contains concise information about the medicine. If you have further questions, refer to the doctor, pharmacist or nurse.

This medicine has been prescribed for you. Do not pass it on to others. It may harm them, even if it seems to you that their medical condition is similar.

**1. WHAT IS THE MEDICINE INTENDED FOR?**

- Treatment of moderate-to-severe atopic dermatitis in adults and children from six months of age and above, when inadequately controlled by prescription medicines for topical treatment or when the patient cannot use topical treatment. Dupixent may be used with or without topical corticosteroids.
- Maintenance treatment of moderate-to-severe asthma in adults and children from the age of six years and above, in combination with other asthma medicines in patients whose asthma is not controlled by their asthma medications. Dupixent helps prevent severe asthma attacks and can improve breathing. Dupixent may also help reduce the amount of oral corticosteroids the patient takes, while preventing severe asthma attacks and improving breathing. Dupixent is not used to treat sudden breathing problems.
- Dupixent 300 mg is used with other medicines to treat chronic rhinosinusitis with nasal polyposis in adults whose disease is not controlled.
- Dupixent 300 mg is used to treat eosinophilic esophagitis in adults and children from the age of 12 years, who weigh at least 40 kg.
- Dupixent 300 mg is used to treat moderate to severe prurigo nodularis in adults eligible for systemic treatment.

**Therapeutic group:** Non-corticosteroidal treatments for the skin and for dermatitis.

Dupixent acts by blocking two proteins that cause a type of inflammation that plays a central role in eczema/atopic dermatitis, asthma, chronic rhinosinusitis with nasal polyposis, eosinophilic esophagitis and prurigo nodularis.

**2. BEFORE USING THE MEDICINE**

**Do not use the medicine:**

if you are sensitive (allergic) to dupilumab or to any of the additional ingredients contained in the medicine (see section 6).

**Special warnings regarding use of the medicine**

Before treatment with Dupixent, talk with the doctor about all your medical conditions, including if:

- you have eye problems.
- you have an intestinal parasitic infection.
- you are scheduled to receive any vaccinations. You should not receive a "live vaccine" right before and during treatment with Dupixent.

**Children and adolescents**

- Dupixent is not intended for treatment of atopic dermatitis in children under 6 months of age.
- Dupixent is not intended for the treatment of asthma in children under 6 years of age.
- Dupixent is not intended for the treatment of chronic rhinosinusitis with nasal polyposis in children and adolescents under 18 years of age.
- Dupixent is not intended for the treatment of eosinophilic esophagitis in children under 12 years of age and who weigh at least 40 kg.
- Dupixent is not intended for the treatment of prurigo nodularis in children and adolescents under 18 years of age.

**Drug interactions**

**If you are taking, or have recently taken, other medicines, including non-prescription medicines and nutritional supplements, tell the doctor or pharmacist,** especially if:

- you are taking oral, topical, or inhaled corticosteroid medicines.
- you have asthma and are taking asthma medicines.
- you have atopic dermatitis, chronic rhinosinusitis with nasal polyposis, eosinophilic esophagitis or prurigo nodularis and also asthma.

**Do not** change or stop taking your corticosteroids or asthma medicines without consulting the doctor. This may cause other effects, which were already under control by the corticosteroids or asthma medicine, to come back.

**Pregnancy, breastfeeding and fertility**

If you are pregnant, think you may be pregnant, are planning to become pregnant, or are breastfeeding, consult with your doctor before taking any medicine.

- The effect of this medicine on the unborn baby is unknown.
- It is not known whether Dupixent passes into breast milk.

**Important information regarding some of the ingredients of the medicine**

Dupixent contains less than 1 mmol (23 mg) sodium per 300 mg dose, i.e., it is essentially "sodium-free".

**3. HOW SHOULD YOU USE THE MEDICINE?**

**Thoroughly read the "Instructions for Use" enclosed with the leaflet for information on how to prepare and inject Dupixent, how to properly store the medicine and how to dispose of used Dupixent syringes.**

Always use the preparation according to the doctor's instructions. Check with the doctor or pharmacist if you are not sure about the dosage and treatment regimen of the preparation.

Dupixent is given by injection under the skin (subcutaneous injection).

If your doctor or nurse decides that you or your caregiver can administer the Dupixent injection, you or your caregiver must receive training on the right way to prepare and perform the injection.

909634



Solution for injection in a pre-filled syringe with needle shield

Dupixent 300 mg

דופיקסנט 300 מ"ג  
נוויקסנט 300 מל"ג

**Do not** attempt to inject Dupixent before being trained by the doctor or nurse.

The Dupixent **syringe** is not intended for use in children **under 6 months of age**.

For children from age 12 years and above, it is recommended that the Dupixent injection be given by or under the supervision of an adult.

For children 6 months to 12 years of age, the Dupixent injection must be administered by a caregiver.

**How much Dupixent to inject and for how long**

The dosage and treatment regimen will be determined by the doctor only.

Each syringe of Dupixent 300 mg contains one dose of Dupixent (300 mg).

**Recommended dosage for adults with atopic dermatitis:**

- Starting dose of 600 mg (two 300 mg injections).
- Thereafter, 300 mg every two weeks.

**Recommended dosage for children 6 years to 17 years of age with atopic dermatitis:**

Body weight	Initial loading dose	Subsequent doses
15 kg to less than 30 kg	600 mg (two 300 mg injections)	300 mg every 4 weeks
30 kg to less than 60 kg	400 mg (two 200 mg injections)	200 mg every 2 weeks
60 kg or more	600 mg (two 300 mg injections)	300 mg every 2 weeks

**Recommended dosage for children 6 months to 5 years of age with atopic dermatitis:**

Body weight	Initial dosage* and subsequent doses
5 kg to less than 15 kg	200 mg (one 200 mg injection) every 4 weeks
15 kg to less than 30 kg	300 mg (one 300 mg injection) every 4 weeks

\*for children 6 months to 5 years of age with atopic dermatitis, an initial loading dose is not recommended.

**Recommended dosage for adults and children from the age of 12 years and above with asthma:**

Initial loading dose	Subsequent doses
400 mg (two 200 mg injections)	200 mg every 2 weeks
<b>OR</b>	
600 mg (two 300 mg injections)	300 mg every 2 weeks
Dosage for patients with asthma who are dependent on oral corticosteroids or patients with asthma and comorbid moderate-to-severe atopic dermatitis or adults with chronic rhinosinusitis with nasal polyposis	
600 mg (two 300 mg injections)	300 mg every 2 weeks

**Recommended dosage for children 6 years to 11 years of age with asthma:**

Body weight	Initial dose* and subsequent doses
15 kg to less than 30 kg	300 mg every 4 weeks
30 kg or more	200 mg every 2 weeks

\*for children 6 to 11 years of age with asthma, an initial loading dose is not recommended.

For children 6 to 11 years of age with asthma and concomitant moderate-to-severe atopic dermatitis, follow the table showing the recommended dosage for children 6 to 17 years of age with atopic dermatitis, which includes an initial loading dose.

**Dosage for adults with chronic rhinosinusitis with nasal polyposis:**

The recommended dosage is 300 mg every two weeks.

**Dosage for adults and children from the age of 12 years with eosinophilic esophagitis:**

The recommended dosage for adults and children from the age of 12 years, who weigh at least 40 kg, is 300 mg every week.

**Dosage for adults with prurigo nodularis:**

The recommended dosage is an initial dose of 600 mg (two 300 mg injections) and then 300 mg every two weeks.

**Do not exceed the recommended dose.**

**If you use more Dupixent than needed**

If you used more Dupixent than needed or the dose has been given too early, get medical help right away.

**If you forgot to use Dupixent**

If you forgot to inject a dose of Dupixent, refer to your doctor, pharmacist or nurse.

**If you stop using Dupixent**

Do not stop using Dupixent without first consulting with the doctor.

Your doctor may recommend use of additional medicines together with Dupixent. Use the other medicines exactly as instructed by your doctor.

**Do not take medicines in the dark! Check the label and dose each time you take medicine. Wear glasses if you need them. If you have further questions regarding use of the medicine, consult the doctor or pharmacist.**

**4. SIDE EFFECTS**

Like any medicine, use of Dupixent may cause side effects in some users. Do not be alarmed when reading the list of side effects. You may not suffer from any of them.

**Dupixent can cause serious side effects including:**

- Allergic reactions. Dupixent can cause allergic reactions that can sometimes be severe.**

Stop using Dupixent and refer to your doctor or an emergency center immediately if one or more of the following signs or symptoms occur:

- breathing problems or wheezing, swelling of the face, lips, mouth, tongue or throat, fainting, dizziness, lightheadedness, fast pulse, fever, general ill feeling, swollen lymph nodes, joint pain, hives, itching, skin rash, nausea or vomiting, cramps in the area of the stomach.

- Eye problems.** Tell your doctor if you have any new or worsening eye problems, including eye pain or vision changes, such as blurred vision. Your doctor may send you to an ophthalmologist for an eye examination, if needed.

- Inflammation of blood vessels.** Rarely, patients suffering from asthma may develop this effect. This happens to people who are also taking an oral steroid, but who stop taking it or the dosage is lowered. It is not known whether this is caused as a result of Dupixent. Tell the doctor immediately if you have: a rash, chest pain, worsening of shortness of breath, a feeling of pins and needles or numbness of your arms or legs, persistent fever.

- Joint pains.** Joint pains can happen in people who use Dupixent. Some people had trouble walking or moving due to their joint symptoms, and in some cases required hospitalization. Tell your doctor about new or worsening joint symptoms. Your doctor may stop Dupixent if you develop joint symptoms.

**The most common side effects of Dupixent:**

- injection site reactions
- upper respiratory tract infections
- eye and eyelid inflammation, including redness, swelling, and itching, sometimes with blurred vision
- dry eye
- herpes virus infections
- cold symptoms (upper respiratory tract infection)
- pain in the throat (oropharyngeal pain)
- cold sores in the mouth and on the lips
- high count of certain white blood cells (eosinophilia)
- dizziness
- muscle pain
- diarrhea
- trouble sleeping
- toothache
- gastritis
- joint pain
- intestinal parasitic infections

**The following additional side effects have been reported:**

- facial rash or redness

**If a side effect occurs, if any of the side effects worsen, or when you are suffering from a side effect not mentioned in the leaflet, consult with the doctor.**

Side effects can be reported to the Ministry of Health by clicking on the link "Reporting Side Effects of Drug Treatment" found on the Ministry of Health homepage ([www.health.gov.il](http://www.health.gov.il)) that directs you to the online form for reporting side effects, or by entering the link: <https://sideeffects.health.gov.il>

**5. HOW SHOULD THE MEDICINE BE STORED?**

Avoid poisoning! This medicine and any other medicine must be kept in a safe place out of the reach and sight of children and/or infants in order to avoid poisoning. Do not induce vomiting unless explicitly instructed to do so by the doctor.

Do not use the medicine after the expiry date (exp. date) that appears on the package. The expiry date refers to the last day of that month.

**Storage conditions:**

Do not store different medicines in the same package. Store in the original package in order to protect from light. Store in a refrigerator (2°-8°C). Do not freeze. Do not shake. Do not heat or expose the Dupixent syringe to direct sunlight.

If necessary, the syringes can be stored at a room temperature of up to 25°C for a maximum of 14 days. Do not store at a temperature exceeding 25°C. If you take the carton out of the refrigerator, write the removal date on the outer package and use Dupixent within 14 days. Do not return the medicine to the refrigerator.

Do not use the medicine if it is cloudy, discolored or contains particles. Do not discard medicines into the household waste bin. Ask your pharmacist how to dispose of medicines you no longer need. These measures will help protect the environment.

**6. FURTHER INFORMATION**

In addition to the active ingredient, the medicine also contains the following inactive ingredients:

Each Dupixent 300 mg syringe contains: Sucrose (100 mg), L-arginine monohydrochloride, L-histidine monohydrochloride monohydrate, L-histidine, polysorbate 80, glacial acetic acid, sodium acetate trihydrate, water for injections.

What the medicine looks like and the contents of the package: Each glass pre-filled syringe contains 300 mg dupilumab in 2 ml of clear to slightly opaque, colorless to pale yellow solution.

The package contains: 1, 2, 3 or 6 pre-filled syringes with a needle shield.

Not all package sizes may be marketed.

This leaflet does not contain all the information about the medicine. If you have any question or are not sure about anything, please refer to the doctor.

**License holder and importer's name and address:**

Sanofi Israel Ltd., Greenwork Park P.O. box 47 Yakum.

Registration number of the medicine in the National Drug Registry of the Ministry of Health: 1602235266

Revised in February 2024 according to MOH guidelines.

<b>Packaging Administration</b>		<b>Sanofi Winthrop Industrie - Le Trait - France</b>		<b>sonofi</b>	
Formal name	DUPIXENT	Article	240072024	Batch/serial	TRK241031K
Dosage	300 mg	Item code	909634	TRK area	TRK241031K
Quantity	2 x 300	Based on	909624	Size (ml)	300 mg/2 ml
Country	Israel	Form of modification	-	2x2 ml pre-filled	
Form of modification	1	Form of modification	1	Color	Yellow
Color	Blue	Color	Blue	Color	Black
Color	Green	Color	Green	Color	Pink
Color	Yellow	Color	Yellow	Color	Pink
Color	Black	Color	Black	Color	Pink

This artwork proof indicates colour position only. Please refer to the final artwork for the actual packaging.

**INSTRUCTIONS FOR USE**

**Dupixent 300 mg pre-filled syringe**

Read the Instructions for Use before using the Dupixent pre-filled syringe.

**Do not inject yourself or anyone else until you have been shown how to inject Dupixent.**

A healthcare provider can show you or your caregiver how to prepare and inject a dose of Dupixent before you try to do it yourself for the first time. Keep these instructions for future use. Call your healthcare provider if you have questions.

This device is a **single-dose** pre-filled syringe (called a "syringe" in these instructions). It contains 300 mg of Dupixent for injection under the skin (subcutaneous injection).

The parts of the Dupixent pre-filled syringe with a needle shield are displayed in the following picture:

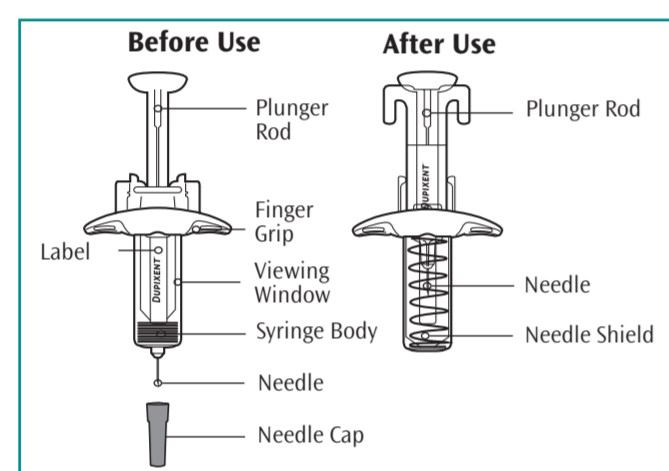

**Step 7: Clean**

Wash your hands.  
Clean the injection site with an alcohol wipe.  
Let your skin dry before injecting.

**▲ Do not touch the injection site again or blow on it before the injection.**

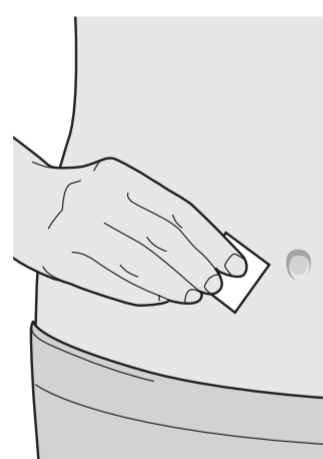

**IMPORTANT INFORMATION**

- Read all of the instructions carefully before using the syringe.
- Check with your healthcare provider on how often you will need to inject the medicine.
- **In children aged 12 years and above**, it is recommended that Dupixent be given by or under the supervision of an adult.
- **In children aged 6 months to under 12 years**, Dupixent injection is to be given by a caregiver.
- Change the injection site for each injection.
- **Do not** use the syringe if it has been dropped on a hard surface or damaged.
- **Do not** touch the plunger rod until you are ready to inject.
- **Do not** inject through clothes.
- **Do not** get rid of any air bubbles from the syringe.
- To reduce the risk of accidental needle injury, the syringe has a needle shield that is automatically activated to cover the needle after the injection.
- **Never** pull back on the plunger rod.
- **Do not** remove the needle cap until just before the injection.
- Throw away the used single-dose syringe immediately after use.
- **Do not reuse a Dupixent syringe.**

**Step 8: Remove the needle cap**

Hold the syringe in the middle of the syringe body with the needle pointing away from you and pull off the needle cap.

**▲ Do not put the needle cap back on.**

**▲ Do not touch the needle.**

Inject your medicine immediately after removing the needle cap.

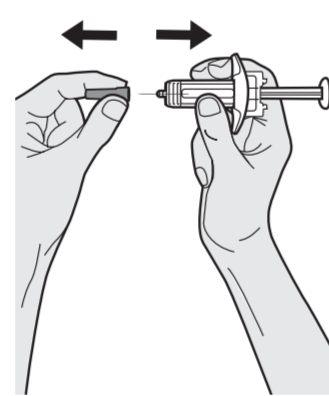

**How to store Dupixent**

- **Keep the Dupixent syringes and other medicines out of the reach and sight of children.**
- Store the syringes in the refrigerator, at a temperature between 2°-8°C.
- Store the syringes in the original package to protect from light.
- The syringes can be stored at room temperature (up to 25°C) for up to 14 days. Throw away syringes that were left at room temperature for more than 14 days.
- **Do not** shake the syringe.
- **Do not** heat the syringe.
- **Do not** freeze the syringe.
- **Do not** put the Dupixent syringe into direct sunlight.

**Step 1: Remove**

Remove the syringe from the carton by holding the middle of the syringe body.

**▲ Do not pull off the needle cap until you are ready to inject.**

**▲ Do not use the syringe if it has been dropped on a hard surface or damaged.**

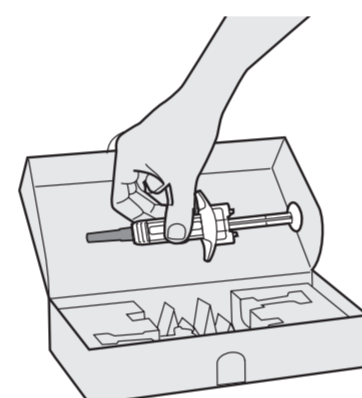

**Step 2: Prepare**

Ensure you have the following items:

- the Dupixent pre-filled syringe
- an alcohol wipe\*
- a cotton ball or gauze pad\*
- a puncture-resistant container\* (see Step 13)

\*These items are not included in the product package.

**Step 3: Check**

When you receive your Dupixent syringes, always check that:

- you have the correct preparation and the correct dosage.
- the expiry date on the syringes has not passed.

**▲ Do not use the syringe if the expiry date has passed.**

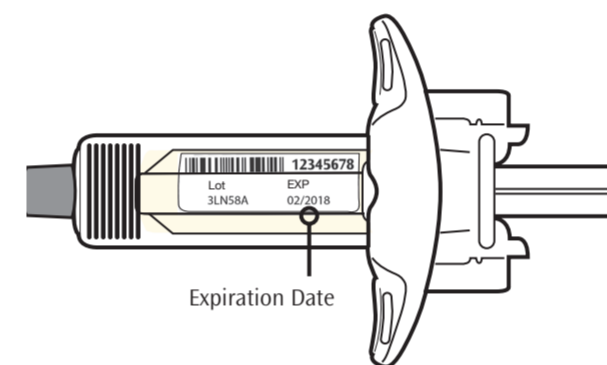

**Step 4: Inspect**

Look at the medicine through the viewing window on the syringe. Check if the liquid is clear and colorless to a pale yellow shade.

*Note: You may see an air bubble; this is normal.*

**▲ Do not use the syringe if the liquid is discolored or cloudy, or if it contains visible flakes or particles.**

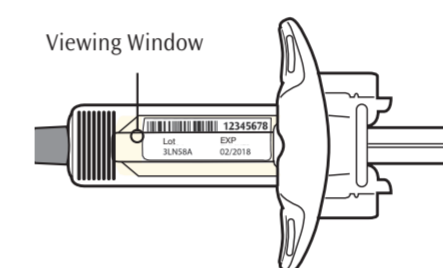

**Step 5: Wait 45 minutes**

Lay the syringe on a flat surface for at least 45 minutes and allow it to reach room temperature naturally.

**▲ Do not heat the syringe.**

**▲ Do not put the Dupixent Syringe into direct sunlight.**

**▲ Do not leave Dupixent at room temperature for more than 14 days. Discard Dupixent syringes that were left at room temperature for more than 14 days.**

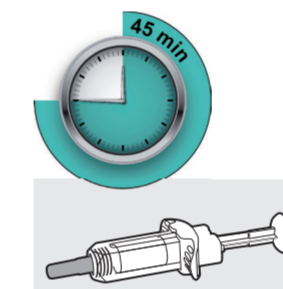

**Step 12: Release and remove**

Lift your thumb to release the plunger until the needle is covered by the needle shield and then remove the syringe from the injection site.

Gently press a cotton ball or gauze pad on the injection site if you see any blood.

**▲ Do not put the needle cap back on.**

**▲ Do not rub your skin after the injection.**

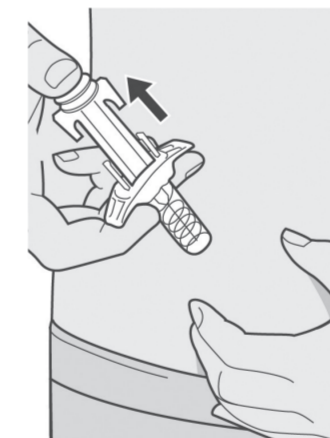

**Step 6: Choose your injection site**

- You can inject into the thigh or stomach, except for the 5 cm around your navel.
- If your caregiver gives you the injection, he can also inject into the outer part of your upper arm.
- Choose a different injection site each time you inject Dupixent.

**▲ Do not inject into skin that is tender, damaged, bruised or scarred.**

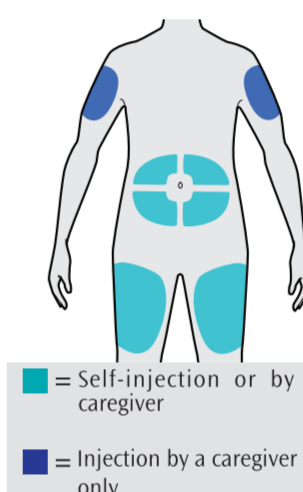

- = Self-injection or by a caregiver
- = Injection by a caregiver only

**Step 13: Dispose**

Dispose of used needles, the syringe and the needle cap in a puncture-resistant container, immediately after use.

**▲ Do not throw away needles, Dupixent Syringes and needle caps in your household trash.**

**▲ Do not put the needle cap back on.**

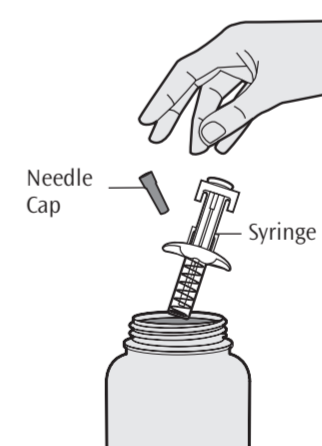

Packaging Administration		Sanofi Winthrop Industrie - Le Trait - France		sonofi	
Formular name	DUPIXENT	Article	Lot/lot number	230072024	Expiration date
Dosage	300 mg	Item code	909534	By	1 Medicine
Quantity	2/300	Based on	909524	Date of modification	-
Country	France	Lot	1	Size (ml)	2.5 x 100 ml/100 ml
This artwork must indicate colour positions only.		Colors	■ Cyan	■ Magenta	■ Yellow
Printed in France on 100% recycled paper.		■ Black	■ Blue		