

Rotarix™ Suspension

1. NAME OF THE MEDICINAL PRODUCT

Rotarix Suspension

2. QUALITATIVE AND QUANTITATIVE COMPOSITION

1 dose (1.5 mL) contains:

Human rotavirus RIX4414 strain (live, attenuated)* not less than $10^{6.0}$ CCID₅₀

*Produced on Vero cells

Excipients with known effect:

This product contains 1073 mg of sucrose, 32 mg of sodium, 10 micrograms of glucose and 0.15 microgram of phenylalanine per dose (see section 4.4).

For the full list of excipients, see section 6.1.

3. PHARMACEUTICAL FORM

Oral suspension.

Rotarix is a clear and colourless liquid.

4. CLINICAL PARTICULARS

4.1 Therapeutic indications

Rotarix is indicated for the active immunisation of infants from the age of 6 weeks for prevention of gastro-enteritis due to rotavirus infection (see sections 4.2, 4.4 and 5.1).

In clinical trials, efficacy was demonstrated against gastro-enteritis due to rotavirus of types G1P[8], G2P[4], G3P[8], G4P[8] and G9P[8] (see sections 4.4 and 5.1).

The use of Rotarix should be based on official recommendations.

4.2 Posology and method of administration

Posology

The vaccination course consists of two doses. The first dose may be administered from the age of 6 weeks. There should be an interval of at least 4 weeks between doses. The vaccination course should preferably be given before 16 weeks of age, but must be completed by the age of 24 weeks.

Rotarix may be given with the same posology to preterm infants born after at least 27 weeks of gestational age (see sections 4.8 and 5.1).

In clinical trials, spitting or regurgitation of the vaccine has rarely been observed and, under such circumstances, a replacement dose was not given. However, in the unlikely event that an infant spits out or regurgitates most of the vaccine dose, a single replacement dose may be given at the same vaccination visit.

It is recommended that infants who receive a first dose of Rotarix complete the 2-dose regimen with Rotarix. There are no data on safety, immunogenicity or efficacy when Rotarix is administered for the first dose and another rotavirus vaccine is administered for the second dose or vice versa.

Paediatric population

Rotarix should not be used in children over 24 weeks of age.

Method of administration

Rotarix is for **oral** use only.

Rotarix should under no circumstances be injected.

For instructions for administration, see section 6.6.

4.3 Contraindications

Hypersensitivity to the active substance or to any of the excipients listed in section 6.1.

Hypersensitivity after previous administration of rotavirus vaccines.

History of intussusception.

Subjects with uncorrected congenital malformation of the gastrointestinal tract that would predispose for intussusception.

Subjects with Severe Combined Immunodeficiency (SCID) disorder (see section 4.8).

Administration of Rotarix should be postponed in subjects suffering from acute severe febrile illness. The presence of a minor infection is not a contra-indication for immunisation.

The administration of Rotarix should be postponed in subjects suffering from diarrhoea or vomiting.

4.4 Special warnings and precautions for use

It is good clinical practice that vaccination should be preceded by a review of the medical history especially with regard to the contraindications and by a clinical examination.

There are no data on the safety and efficacy of Rotarix in infants with gastrointestinal illnesses or growth retardation. Administration of Rotarix may be considered with caution in such infants when, in the opinion of the physician, withholding the vaccine entails a greater risk.

As a precaution, healthcare professionals should follow-up on any symptoms indicative of intussusception (severe abdominal pain, persistent vomiting, bloody stools, abdominal bloating and/or high fever) since data from observational safety studies indicate an increased risk of intussusception, mostly within 7 days after rotavirus vaccination (see section 4.8). Parents/guardians should be advised to promptly report such symptoms to their healthcare provider.

For subjects with a predisposition for intussusception, see section 4.3.

Asymptomatic and mildly symptomatic HIV infections are not expected to affect the safety or efficacy of Rotarix. A clinical study in a limited number of asymptomatic or mildly symptomatic HIV positive infants showed no apparent safety problems (see section 4.8). Administration of Rotarix to infants who have known or suspected immunodeficiency, including *in utero* exposure to an immunosuppressive treatment, should be based on careful consideration of potential benefits and risks.

Excretion of the vaccine virus in the stools is known to occur after vaccination with peak excretion around the 7th day. Viral antigen particles detected by ELISA were found in 50% of stools after the first dose of Rotarix lyophilised formulation and 4% of stools after the second dose. When these stools were tested for the presence of live vaccine strain, only 17% were

positive. In two comparative controlled trials, vaccine shedding after vaccination with Rotarix liquid formulation was comparable to that observed after vaccination with Rotarix lyophilised formulation.

Cases of transmission of this excreted vaccine virus to seronegative contacts of vaccinees have been observed without causing any clinical symptom.

Rotarix should be administered with caution to individuals with immunodeficient close contacts, such as individuals with malignancies, or who are otherwise immunocompromised or individuals receiving immunosuppressive therapy.

Contacts of recent vaccinees should observe personal hygiene (e.g. wash their hands after changing child's nappies).

The potential risk of apnoea and the need for respiratory monitoring for 48-72h should be considered when administering the primary immunisation series to very premature infants (born \leq 28 weeks of gestation) and particularly for those with a previous history of respiratory immaturity.

As the benefit of the vaccination is high in this group of infants, vaccination should not be withheld or delayed.

A protective immune response may not be elicited in all vaccinees (see section 5.1).

The extent of protection that Rotarix might provide against other rotavirus strains that have not been circulating in clinical trials is currently unknown. Clinical studies from which efficacy data were derived were conducted in Europe, Central and South America, Africa and Asia (see section 5.1).

Rotarix does not protect against gastro-enteritis due to other pathogens than rotavirus.

No data are available on the use of Rotarix for post-exposure prophylaxis.

Rotarix should under no circumstances be injected.

Excipients

This vaccine contains sucrose and glucose as excipients. Patients with rare hereditary problems of fructose intolerance, glucose-galactose malabsorption or sucrase-isomaltase insufficiency should not take this vaccine.

This vaccine contains 0.15 microgram phenylalanine in each dose. Phenylalanine may be harmful for patients with phenylketonuria (PKU).

This vaccine contains 32 mg sodium in each dose.

Traceability

order to improve the traceability of biological medicinal products, the name and the batch number of the administered product should be clearly recorded.

4.5 Interaction with other medicinal products and other forms of interaction

Rotarix can be given concomitantly with any of the following monovalent or combination vaccines [including hexavalent vaccines (DTPa-HBV-IPV/Hib)]: diphtheria-tetanus-whole cell pertussis vaccine (DTPw), diphtheria-tetanus-acellular pertussis vaccine (DTPa), *Haemophilus influenzae* type b vaccine (Hib), inactivated polio vaccine (IPV), hepatitis B vaccine (HBV), pneumococcal conjugate vaccine and meningococcal serogroup C conjugate vaccine. Clinical studies demonstrated that the immune responses and the safety profiles of the administered vaccines were unaffected.

Concomitant administration of Rotarix and oral polio vaccine (OPV) does not affect the immune response to the polio antigens. Although concomitant administration of OPV may slightly reduce the immune response to rotavirus vaccine, clinical protection against severe rotavirus gastro-enteritis was shown to be maintained in a clinical trial involving more than 4 200 subjects who received Rotarix concomitantly with OPV.

There are no restrictions on the infant's consumption of food or liquid, either before or after vaccination.

4.6 Fertility, pregnancy and lactation

Rotarix is not intended for use in adults. There are no data on the use of Rotarix during pregnancy and lactation.

Based on evidence generated in clinical trials, breast-feeding does not reduce the protection against rotavirus gastro-enteritis afforded by Rotarix. Therefore, breast-feeding may be continued during the vaccination schedule.

4.7 Effects on ability to drive and use machines

Not relevant.

4.8 Undesirable effects

Summary of the safety profile

The safety profile presented below is based on data from clinical trials conducted with either the lyophilised or the liquid formulation of Rotarix.

In a total of four clinical trials, approximately 3 800 doses of Rotarix liquid formulation were administered to approximately 1 900 infants. Those trials have shown that the safety profile of the liquid formulation is comparable to the lyophilised formulation.

In a total of twenty-three clinical trials, approximately 106 000 doses of Rotarix (lyophilised or liquid formulation) were administered to approximately 51 000 infants.

In three placebo-controlled clinical trials (Finland, India and Bangladesh), in which Rotarix was administered alone (administration of routine paediatric vaccines was staggered), the incidence and severity of the solicited events (collected 8 days post-vaccination), diarrhoea, vomiting, loss of appetite, fever, irritability and cough/runny nose were not significantly different in the group receiving Rotarix when compared to the group receiving placebo. No increase in the incidence or severity of these events was seen with the second dose.

In a pooled analysis from seventeen placebo-controlled clinical trials (Europe, North America, Latin America, Asia, Africa) including trials in which Rotarix was co-administered with routine paediatric vaccines (see section 4.5), the following adverse reactions (collected 31 days post-vaccination) were considered as possibly related to vaccination.

Tabulated list of adverse reactions

Adverse reactions reported are listed according to the following frequency:

Frequencies are reported as:

Very common	($\geq 1/10$)
Common	($\geq 1/100$ to $< 1/10$)
Uncommon	($\geq 1/1\ 000$ to $< 1/100$)
Rare	($\geq 1/10\ 000$ to $< 1/1\ 000$)
Very rare	($< 1/10\ 000$)

System Organ Class	Frequency	Adverse reactions
Gastrointestinal disorders	Common	Diarrhoea
	Uncommon	Abdominal pain, flatulence
	Very rare	Intussusception (see section 4.4)
	Not known*	Haematochezia
	Not known*	Gastroenteritis with vaccine viral shedding in infants with Severe Combined Immunodeficiency (SCID) disorder
	Uncommon	Dermatitis
	Very rare	Urticaria
General disorders and administration site conditions	Common	Irritability
Respiratory, thoracic and mediastinal disorders	Not known*	Apnoea in very premature infants (≤ 28 weeks of gestation) (see section 4.4)

* Because these events were reported spontaneously, it is not possible to reliably estimate their frequency.

Description of selected adverse reactions

Intussusception

Data from observational safety studies performed in several countries indicate that rotavirus vaccines carry an increased risk of intussusception, mostly within 7 days of vaccination. Up to 6 additional cases per 100 000 infants have been observed in these countries against a background incidence of 25 to 101 per 100 000 infants (less than one year of age) per year, respectively.

There is limited evidence of a smaller increased risk following the second dose.

It remains unclear whether rotavirus vaccines affect the overall incidence of intussusception based on longer periods of follow-up (see section 4.4).

Other special populations

Safety in preterm infants

In a clinical study, 670 pre-term infants from 27 to 36 weeks of gestational age were administered Rotarix lyophilised formulation and 339 received placebo. The first dose was administered from 6 weeks after birth. Serious adverse events were observed in 5.1% of recipients of Rotarix as compared with 6.8% of placebo recipients. Similar rates of other adverse events were observed in Rotarix and placebo recipients. No cases of intussusception were reported.

Safety in infants with human immunodeficiency (HIV) infection

In a clinical study, 100 infants with HIV infection were administered Rotarix lyophilised formulation or placebo. The safety profile was similar between Rotarix and placebo recipients.

Reporting of suspected adverse reactions

Reporting suspected adverse reactions after authorisation of the medicinal product is important. It allows continued monitoring of the benefit/risk balance of the medicinal product.

Any suspected adverse events should be reported to the Ministry of Health according to the National Regulation by using an online form <https://sideeffects.health.gov.il>
 Additionally, you should also report to GSK Israel (il.safety@gsk.com).

4.9 Overdose

Some cases of overdose have been reported. In general, the adverse event profile reported in these cases was similar to that observed after administration of the recommended dose of Rotarix.

5. PHARMACOLOGICAL PROPERTIES

5.1 Pharmacodynamic properties

Pharmaco-therapeutic group: rotavirus diarrhoea vaccines, ATC code: J07BH01

Protective efficacy of the lyophilised formulation

In clinical trials, efficacy was demonstrated against gastro-enteritis due to rotavirus of the most common genotypes G1P[8], G2P[4], G3P[8], G4P[8] and G9P[8]. In addition, efficacy against uncommon rotavirus genotypes G8P[4] (severe gastro-enteritis) and G12P[6] (any gastro-enteritis) has been demonstrated. These strains are circulating worldwide.

Clinical studies have been conducted in Europe, Latin America, Africa and Asia to evaluate the protective efficacy of Rotarix against any and severe rotavirus gastro-enteritis (RVGE).

Severity of gastro-enteritis was defined according to two different criteria:

- the Vesikari 20-point scale, which evaluates the full clinical picture of rotavirus gastro-enteritis by taking into account the severity and duration of diarrhoea and vomiting, the severity of fever and dehydration as well as the need for treatment
- or
- the clinical case definition based on World Health Organization (WHO) criteria

Clinical protection was assessed in the ATP cohort for efficacy, which includes all subjects from the ATP cohort for safety who entered into the concerned efficacy follow-up period.

Protective efficacy in Europe

A clinical study performed in Europe evaluated Rotarix given according to different European schedules (2, 3 months; 2, 4 months; 3, 4 months; 3, 5 months) in 4 000 subjects.

After two doses of Rotarix, the protective vaccine efficacy observed during the first and second year of life is presented in the following table:

	1st year of life Rotarix N=2 572 Placebo N=1 302		2nd year of life Rotarix N=2 554 Placebo N=1 294	
Vaccine efficacy (%) against any and severe rotavirus gastro-enteritis [95% CI]				
Genotype	Any severity	Severe[†]	Any severity	Severe[†]
G1P[8]	95.6 [87.9;98.8]	96.4 [85.7;99.6]	82.7 [67.8;91.3]	96.5 [86.2;99.6]
G2P[4]	62.0* [<0.0;94.4]	74.7* [<0.0;99.6]	57.1 [<0.0;82.6]	89.9 [9.4;99.8]
G3P[8]	89.9 [9.5;99.8]	100 [44.8;100]	79.7 [<0.0;98.1]	83.1* [<0.0;99.7]
G4P[8]	88.3 [57.5;97.9]	100 [64.9;100]	69.6* [<0.0;95.3]	87.3 [<0.0;99.7]
G9P[8]	75.6	94.7	70.5	76.8

	[51.1;88.5]	[77.9;99.4]	[50.7;82.8]	[50.8;89.7]
Strains with P[8] genotype	88.2 [80.8;93.0]	96.5 [90.6;99.1]	75.7 [65.0;83.4]	87.5 [77.8;93.4]
Circulating rotavirus strains	87.1 [79.6;92.1]	95.8 [89.6;98.7]	71.9 [61.2;79.8]	85.6 [75.8;91.9]
Vaccine efficacy (%) against rotavirus gastro-enteritis requiring medical attention [95% CI]				
Circulating rotavirus strains	91.8 [84;96.3]		76.2 [63.0;85.0]	
Vaccine efficacy (%) against hospitalisation due to rotavirus gastro-enteritis [95% CI]				
Circulating rotavirus strains	100 [81.8;100]		92.2 [65.6;99.1]	

† Severe gastro-enteritis was defined as a score ≥ 11 on the Vesikari scale

* Not statistically significant ($p \geq 0.05$). These data should be interpreted with caution.

Vaccine efficacy during the first year of life progressively increased with increasing disease severity, reaching 100% (95% CI: 84.7;100) for Vesikari scores ≥ 17 .

Protective efficacy in Latin America

A clinical study performed in Latin America evaluated Rotarix in more than 20 000 subjects. Severity of gastro-enteritis (GE) was defined according to WHO criteria. The protective vaccine efficacy against severe rotavirus (RV) gastro-enteritis requiring hospitalisation and/or rehydration therapy in a medical facility and the genotype specific vaccine efficacy after two doses of Rotarix are presented in the table below:

Genotype	Severe rotavirus gastro-enteritis† (1 st year of life) Rotarix N=9 009 Placebo N=8 858	Severe rotavirus gastro-enteritis† (2 nd year of life) Rotarix N=7 175 Placebo N=7 062
	Efficacy (%) [95% CI]	Efficacy (%) [95% CI]
All RVGE	84.7 [71.7;92.4]	79.0 [66.4;87.4]
G1P[8]	91.8 [74.1;98.4]	72.4 [34.5;89.9]
G3P[8]	87.7 [8.3;99.7]	71.9* [<0.0;97.1]
G4P[8]	50.8#* [<0.0;99.2]	63.1 [0.7;88.2]
G9P[8]	90.6 [61.7;98.9]	87.7 [72.9;95.3]
Strains with P[8] genotype	90.9 [79.2;96.8]	79.5 [67.0;87.9]

† Severe rotavirus gastro-enteritis was defined as an episode of diarrhoea with or without vomiting that required hospitalisation and/or re-hydration therapy in a medical facility (WHO criteria)

* Not statistically significant ($p \geq 0.05$). These data should be interpreted with caution

The numbers of cases, on which the estimates of efficacy against G4P[8] were based, were very small (1 case in the Rotarix group and 2 cases in the placebo group)

A pooled analysis of five efficacy studies*, showed a 71.4% (95% CI: 20.1;91.1) efficacy against severe rotavirus gastro-enteritis (Vesikari score ≥ 11) caused by rotavirus G2P[4] genotype during the first year of life.

* In these studies, the point estimates and confidence intervals were respectively: 100% (95% CI: -1 858.0;100), 100% (95% CI: 21.1;100), 45.4% (95% CI: -81.5;86.6), 74.7% (95% CI: -386.2;99.6). No point estimate was available for the remaining study.

Protective efficacy in Africa

A clinical study performed in Africa (Rotarix: N = 2 974; placebo: N = 1 443) evaluated Rotarix given at approximately 10 and 14 weeks of age (2 doses) or 6, 10 and 14 weeks of age (3 doses). The vaccine efficacy against severe rotavirus gastro-enteritis during the first year of life was 61.2% (95% CI: 44.0;73.2). The protective vaccine efficacy (pooled doses) observed against any and severe rotavirus gastro-enteritis is presented in the following table:

Genotype	Any rotavirus gastro-enteritis Rotarix N=2 974 Placebo N=1 443	Severe rotavirus gastro-enteritis† Rotarix N=2 974 Placebo N=1 443
	Efficacy (%) [95% CI]	Efficacy (%) [95% CI]
G1P[8]	68.3 [53.6;78.5]	56.6 [11.8;78.8]
G2P[4]	49.3 [4.6;73.0]	83.8 [9.6;98.4]
G3P[8]	43.4* [<0.0;83.7]	51.5* [<0.0;96.5]
G8P[4]	38.7* [<0.0;67.8]	63.6 [5.9;86.5]
G9P[8]	41.8* [<0.0;72.3]	56.9* [<0.0;85.5]
G12P[6]	48.0 [9.7;70.0]	55.5* [<0.0; 82.2]
Strains with P[4] genotype	39.3 [7.7;59.9]	70.9 [37.5;87.0]
Strains with P[6] genotype	46.6 [9.4;68.4]	55.2* [<0.0;81.3]
Strains with P[8] genotype	61.0 [47.3;71.2]	59.1 [32.8;75.3]

† Severe gastro-enteritis was defined as a score ≥ 11 on the Vesikari scale

* Not statistically significant ($p \geq 0.05$). These data should be interpreted with caution.

Sustained efficacy up to 3 years of age in Asia

A clinical study conducted in Asia (Hong Kong, Singapore and Taiwan) (Total vaccinated cohort: Rotarix: N = 5 359; placebo: N = 5 349) evaluated Rotarix given according to different schedules (2, 4 months of age; 3, 4 months of age).

During the first year, significantly fewer subjects in the Rotarix group reported severe rotavirus gastro-enteritis caused by the circulating wild-type RV compared to the placebo group from 2 weeks after Dose 2 up to one year of age (0.0% versus 0.3%), with a vaccine efficacy of 100% (95% CI: 72.2;100).

The protective vaccine efficacy after two doses of Rotarix observed against severe rotavirus gastro-enteritis up to 2 years of age is presented in the following table:

Efficacy up to 2 years of age Rotarix N= 5 263 Placebo N= 5 256	
Vaccine efficacy (%) against severe rotavirus gastro-enteritis [95% CI]	
Genotype	Severe†
G1P[8]	100 [80.8;100]
G2P[4]	100* [<0.0;100]
G3P[8]	94.5 [64.9;99.9]
G9P[8]	91.7 [43.8;99.8]
Strains with P[8] genotype	95.8 [83.8;99.5]
Circulating rotavirus strains	96.1 [85.1;99.5]
Vaccine efficacy (%) against rotavirus gastro-enteritis requiring hospitalisation and/or rehydration therapy in a medical facility [95% CI]	
Circulating rotavirus strains	94.2 [82.2;98.8]

† Severe gastro-enteritis was defined as a score ≥ 11 on the Vesikari scale

* Not statistically significant ($p \geq 0.05$). These data should be interpreted with caution.

During the third year of life, there were no cases of severe RV gastro-enteritis in the Rotarix group (N=4 222) versus 13 (0.3%) in the placebo group (N=4 185). Vaccine efficacy was 100% (95% CI: 67.5; 100). The severe RV gastro-enteritis cases were due to RV strains G1P[8], G2P[4], G3P[8] and G9P[8]. The incidence of severe RV gastro-enteritis associated with the individual genotypes was too small to allow calculation of efficacy. The efficacy against severe RV gastro-enteritis requiring hospitalisation was 100% (95% CI: 72.4;100).

Protective efficacy of the liquid formulation

Since the immune response observed after 2 doses of Rotarix liquid formulation was comparable to the immune response observed after 2 doses of Rotarix lyophilised formulation, the levels of vaccine efficacy observed with the lyophilised formulation can be extrapolated to the liquid formulation.

Immune response

The immunologic mechanism by which Rotarix protects against rotavirus gastro-enteritis is not completely understood. A relationship between antibody responses to rotavirus vaccination and protection against rotavirus gastro-enteritis has not been established.

The following table shows the percentage of subjects initially seronegative for rotavirus (IgA antibody titres < 20 U/mL) (by ELISA) with serum anti-rotavirus IgA antibody titres ≥ 20 U/mL one to two months after the second dose of vaccine or placebo as observed in different studies with Rotarix lyophilised formulation.

Schedule	Studies conducted in	Vaccine		Placebo	
		N	% ≥ 20 U/mL [95% CI]	N	% ≥ 20 U/mL [95% CI]
2, 3 months	France, Germany	239	82.8 [77.5;87.4]	127	8.7 [4.4;15.0]
2, 4 months	Spain	186	85.5 [79.6;90.2]	89	12.4 [6.3;21.0]
3, 5 months	Finland, Italy	180	94.4 [90.0;97.3]	114	3.5 [1.0;8.7]
3, 4 months	Czech Republic	182	84.6 [78.5;89.5]	90	2.2 [0.3;7.8]
2, 3 to 4 months	Latin America; 11 countries	393	77.9% [73.8;81.6]	341	15.1% [11.7;19.0]

10, 14 weeks and 6, 10, 14 weeks (Pooled)	South Africa, Malawi	221	58.4 [51.6;64.9]	111	22.5 [15.1;31.4]
--	----------------------	-----	---------------------	-----	---------------------

In three comparative controlled trials, the immune response elicited by Rotarix liquid formulation was comparable to the one elicited by Rotarix lyophilised formulation.

Immune response in preterm infants

In a clinical study conducted in preterm infants, born after at least 27 weeks of gestational age, the immunogenicity of Rotarix was assessed in a subset of 147 subjects and showed that Rotarix is immunogenic in this population; 85.7% (95% CI: 79.0;90.9) of subjects achieved serum anti-rotavirus IgA antibody titres ≥ 20 U/mL (by ELISA) one month after the second dose of vaccine.

Effectiveness

In observational studies, vaccine effectiveness was demonstrated against severe gastro-enteritis leading to hospitalisation due to rotavirus of common genotypes G1P[8], G2P[4], G3P[8], G4P[8] and G9P[8] as well as the less common rotavirus genotypes G9P[4] and G9P[6]. All of these strains are circulating worldwide.

Effectiveness after 2 doses in preventing RVGE leading to hospitalisation

Countries Period	Age range	N ⁽¹⁾ (cases/controls)	Strains	Effectiveness % [95% CI]
High Income countries				
Belgium 2008-2010 ⁽²⁾	< 4 yrs	160/198	All	90 [81;95]
	3-11 m			91 [75;97]
	< 4 yrs	41/53	G1P[8]	95 [78;99]
	< 4 yrs	80/103	G2P[4]	85 [64;94]
	3-11 m		83 [22;96] ⁽³⁾	
< 4 yrs	12/13	G3P[8]	87* [<0 ;98] ⁽³⁾	
< 4 yrs	16/17	G4P[8]	90 [19;99] ⁽³⁾	
Singapore 2008-2010 ⁽²⁾	< 5 yrs	136/272	All	84 [32;96]
		89/89	G1P[8]	91 [30;99]
Taiwan 2009-2011	< 3 yrs	184/1 623 ⁽⁴⁾	All	92 [75;98]
			G1P[8]	95 [69;100]
US 2010-2011	< 2 yrs	85/1 062 ⁽⁵⁾	All	85 [73;92]
			G1P[8]	88 [68;95]
	G2P[4]		88 [68;95]	
8-11 m	All	89 [48;98]		
US 2009-2011	< 5 yrs	74/255 ⁽⁴⁾	All	68 [34;85]
Middle Income Countries				
Bolivia 2010-2011	< 3 yrs	300/974	All	77 [65;84] ⁽⁶⁾
	6-11 m			77 [51;89]
	< 3 yrs		G9P[8]	85 [69;93]
	6-11 m		G3P[8]	90 [65;97]
	< 3 yrs		G2P[4]	69 [14;89]
	G9P[6]		87 [19;98]	
Brazil 2008-2011	< 2 yrs	115/1 481	All	72 [44;85] ⁽⁶⁾
			G1P[8]	89 [78;95]
			G2P[4]	76 [64;84]
Brazil 2008-2009 ⁽²⁾	< 3 yrs	249/249 ⁽⁵⁾	All	76 [58;86]
3-11 m	96 [68;99]			

	< 3 yrs 3-11 m	222/222 ⁽⁵⁾	G2P[4]	75 [57;86] 95 [66;99] ⁽³⁾
El Salvador 2007-2009	< 2 yrs 6-11 m	251/770 ⁽⁵⁾	All	76 [64;84] ⁽⁶⁾ 83 [68;91]
Guatemala 2012-2013	< 4 yrs	NA ⁽⁷⁾	All	63 [23;82]
Mexico 2010	< 2 yrs	9/17 ⁽⁵⁾	G9P[4]	94 [16;100]
Low Income Countries				
Malawi 2012-2014	< 2 yrs	81/286 ⁽⁵⁾	All	63 [23;83]

m: months

yrs: years

* Not statistically significant ($p \geq 0.05$). These data should be interpreted with caution.

- (1) The number of fully vaccinated (2 doses) and unvaccinated cases and controls is given.
- (2) GSK sponsored studies
- (3) Data from a post-hoc analysis
- (4) Vaccine effectiveness was calculated using rotavirus-negative hospital control participants (estimates from Taiwan were calculated using combined rotavirus-negative hospital control and non-diarrhoea hospital control participants).
- (5) Vaccine effectiveness was calculated using neighbourhood controls.
- (6) In subjects who did not receive the full course of vaccination, the effectiveness after one dose ranged from 51% (95% CI: 26;67, El Salvador) to 60% (95% CI: 37;75, Brazil).
- (7) NA: Not available. Vaccine effectiveness estimate is based on 41 fully vaccinated cases and 175 fully vaccinated controls.

Impact on mortality[§]

Impact studies with Rotarix conducted in Panama, Brazil and Mexico showed a decrease in all-cause diarrhoea mortality ranging from 17% to 73% in children less than 5 years of age, within 2 to 4 years after vaccine introduction.

Impact on hospitalisation[§]

In a retrospective database study in Belgium conducted in children 5 years of age and younger, the direct and indirect impact of Rotarix vaccination on rotavirus-related hospitalisation ranged from 64% (95% CI: 49;76) to 80% (95% CI: 77;83) two years after vaccine introduction. Similar studies in Armenia, Australia, Brazil, Canada, El Salvador and Zambia showed a reduction of 45 to 93% between 2 and 4 years after vaccine introduction.

In addition, nine impact studies on all-cause diarrhoea hospitalisation conducted in Africa and Latin America showed a reduction of 14% to 57% between 2 and 5 years after vaccine introduction.

[§]NOTE: Impact studies are meant to establish a temporal relationship but not a causal relationship between the disease and vaccination. Natural fluctuations of the incidence of the disease may also influence the observed temporal effect.

5.2 Pharmacokinetic properties

Not applicable.

5.3 Preclinical safety data

Non-clinical data reveal no special hazard for humans based on conventional studies of repeated dose toxicity.

6. PHARMACEUTICAL PARTICULARS

6.1 List of excipients

Sucrose

Di-sodium Adipate

Dulbecco's Modified Eagle Medium (DMEM) (containing phenylalanine, sodium, glucose, and other substances)

Sterile water

6.2 Incompatibilities

In the absence of compatibility studies, this medicinal product must not be mixed with other medicinal products.

6.3 Shelf life

The expiry date of the vaccine is indicated on the label and packaging.

The vaccine should be used immediately after opening.

6.4 Special precautions for storage

Store in a refrigerator (2°C – 8°C).

Do not freeze.

Store in the original package, in order to protect from light.

6.5 Nature and contents of container

Pre-filled oral applicator

1.5 mL of **oral** suspension in a pre-filled **oral** applicator (type I glass) with a plunger stopper (rubber butyl) and a protective tip cap (rubber butyl), in pack sizes of 1 or 10.

Squeezable tube

1.5 mL of **oral** suspension in a squeezable tube (polyethylene) fitted with a membrane and a tube cap (polypropylene), in pack sizes of 1, 10 or 50.

Not all pack sizes may be marketed.

6.6 Special precautions for disposal and other handling

The vaccine is presented as a clear, colourless liquid, free of visible particles, for **oral** administration.

The vaccine is ready to use (no reconstitution or dilution is required).

The vaccine is to be administered **orally** without mixing with any other vaccines or solutions.

The vaccine should be inspected visually for any foreign particulate matter and/or abnormal physical appearance. In the event of either being observed, discard the vaccine.

Any unused medicinal product or waste material should be disposed of in accordance with local requirements.

Instructions for administration of the vaccine in a pre-filled oral applicator (*Syringe*)

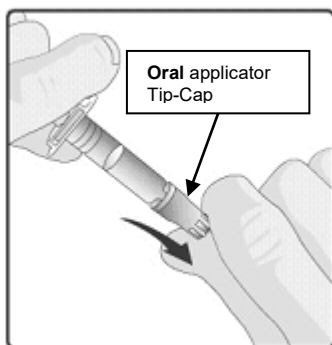

1. Remove the protective tip cap from the oral applicator.



2. This vaccine is for **oral administration only**. The child should be seated in a reclining position. Administer **orally** (i.e. into the child's mouth, towards the inner cheek) the entire content of the **oral** applicator.

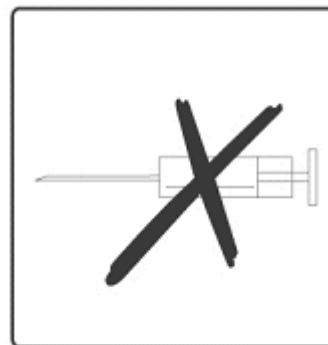

3. **Do not inject.**

Discard the empty **oral** applicator and tip cap in approved biological waste containers according to local regulations.

Instructions for administration of the vaccine in a squeezable tube:

Please read the instructions for use all the way through before starting to give the vaccine.

A What you need to do before giving Rotarix

- Check the expiry date.
- Check the tube has not been damaged nor is already open.
- Check the liquid is clear and colourless, without any particles in it.

If you notice anything abnormal, do not use the vaccine.

- This vaccine is given orally - straight from the tube.
- It is ready to use - you do not need to mix it with anything.

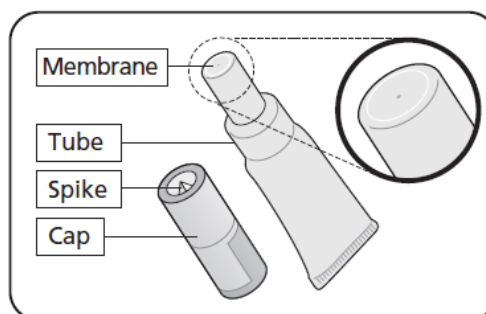

B Get the tube ready

1. Pull off the cap

- Keep the cap – you need this to pierce the membrane.
- Hold the tube upright.

2. Repeatedly flick the top of the tube until it is clear of any liquid

- Clear any liquid from the thinnest section of the tube by flicking just below the membrane.

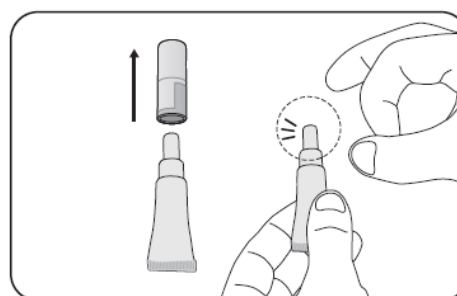

3. Position the cap to open the tube

- Keep the tube held upright.
- Hold the side of tube
- There is a small spike inside the top of the cap - in the centre.
- Turn the cap upside down (180°).

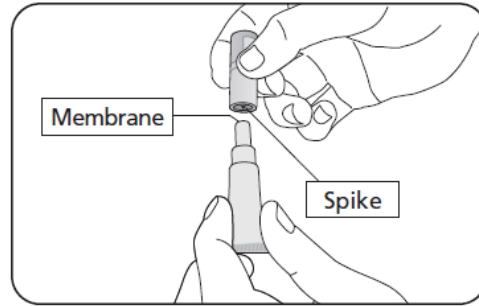

4. To open the tube

- You do not need to twist. Press the cap down to pierce the membrane.
- Then lift off the cap.

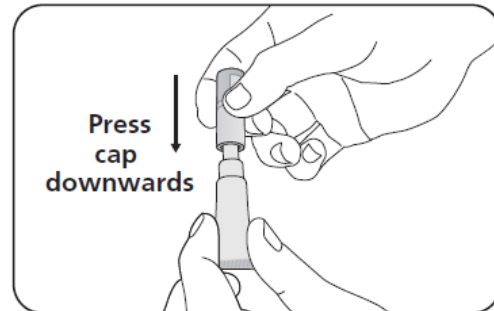

C Check the tube has opened correctly

1. Check the membrane has been pierced

- There should be a hole at the top of the tube.

2. What to do if the membrane has not been pierced

- If the membrane has not been pierced return to section B and repeat steps 2, 3 and 4.

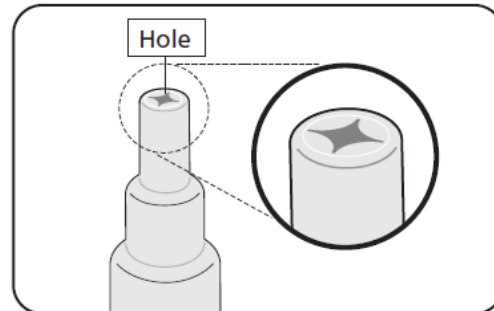

D Give the vaccine

- Once the tube is open check the liquid is clear, without any particles in it.
If you notice anything abnormal, do not use the vaccine.
- Give the vaccine straight away.

1. Position the child to give the vaccine

- Seat the child leaning slightly backwards.

2. Administer the vaccine

- Squeeze the liquid gently into the side of the child's mouth - towards the inside of their cheek.
- You may need to squeeze the tube a few times to get all of the vaccine out - it is okay if a drop remains in the tip of the tube.

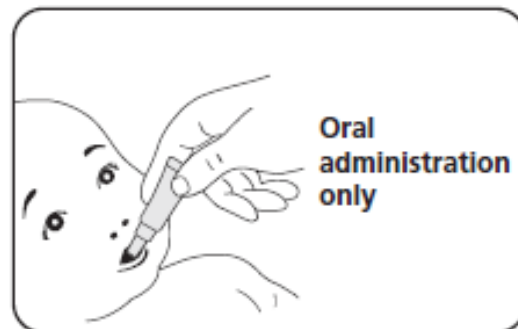

Discard the empty tube and cap in approved biological waste containers according to local regulations.

7. MANUFACTURER

GlaxoSmithKline Biologicals S.A., Rixensart, Belgium.

8. LICENSE HOLDER

GlaxoSmithKline (Israel) Ltd., 25 Basel St., Petach Tikva.

9. LICENSE NUMBER

143-49-32971

RotSus DR v8

Trade marks are owned by or licensed to the GSK group of companies.
©2024 GSK group of companies or its licensor