

Patient package insert according to Pharmacists' Regulations (Preparations) – 1986

This medicine can be sold with a physician's prescription only

Fulphila[®], Prefilled syringe

6 mg/0.6 ml (10 mg/ml)

For subcutaneous administration

Composition:

Each syringe contains: Pegfilgrastim 6 mg/0.6 ml

Inactive ingredients and allergens in the medicine - see section 6 "Additional information" and in section 2 "Important information about some of the ingredients of the medicine".

- **Read this entire leaflet carefully before using this medicine.** This leaflet contains concise information about the medicine. If you have any further questions, ask the doctor, pharmacist, or nurse.
- Also read the instructions for use leaflet of **Fulphila**, which is included in the package.
- Keep this leaflet. You may need to read it again.
- This medicine has been prescribed to treat your illness. Do not pass it on to others. It may harm them, even if you think that their illness is similar.
- If any side effects appear, consult the doctor, pharmacist, or nurse. This includes any possible side effects not listed in this leaflet. See section 4 "Side effects".

Important information for your review

- If you were told you are hypersensitive to certain types of sugars, consult the doctor before using the medicine **Fulphila**.
- The medicine **Fulphila** can be self-injected in your house after receiving instruction from the medical staff. Please carefully read the instructions for self-injection that appear in the instructions for use leaflet included in the package.
- Following the doctor's instructions (dosage, injection times, and duration of treatment) increases the chance of success of the treatment. Do not, under any circumstances, stop the treatment without consulting the attending doctor. Please read sections 2 and 4 for detailed safety information.
- Keep the medicine **Fulphila** in the refrigerator (see section 5 - "How to store the medicine?").
- The medicine, **Fulphila** pre-filled syringe, is intended for single use!

Please note, it is important to make sure you receive the same medicine prescribed to you by the attending specialist doctor each time you receive the medicine at the pharmacy. If the medicine you received looks different from the one you usually receive or the directions for use have changed, please refer immediately to the pharmacist to make sure you have received the correct medicine. Any substitution or dosage change of a medicine that contains pegfilgrastim (the active ingredient in the medicine) must be carried out by the attending specialist doctor only. Check that the trade name of the preparation the specialist doctor prescribed is identical to the name of the medicine you received from the pharmacist.

Fulphila is a bio-similar medicine. For further information about bio-similar medicines, refer to the Ministry of Health website:

<https://www.gov.il/he/Departments/General/biosimilar>

1. What is the medicine intended for?

The medicine **Fulphila** is used to reduce the duration of neutropenia (low white blood cell count) and to reduce the risk of the occurrence of febrile neutropenia (low white blood cell count with fever), which may be caused by cytotoxic chemotherapy (medicines that destroy rapidly growing cells), given at intervals of 14 days or more, for malignancy (with the exception of chronic myeloid leukaemia [CML] and myelodysplastic syndromes [MDS]).

White blood cells are important, as they help your body fight infection. These cells are very sensitive to the effects of chemotherapy, which may cause the number of these cells in your body to decrease. If the number of white blood cells falls below a certain level, the ability of your body to fight bacteria is harmed and you may have an increased risk of infection. Your doctor has given you the medicine **Fulphila** to encourage your bone marrow (part of the bone which makes blood cells) to produce more white blood cells that help your body fight infection.

Therapeutic group

Fulphila is a medicine from the group of proteins called Granulocyte-colony stimulating factor (G-CSF).

The medicine **Fulphila** contains the active ingredient pegfilgrastim. Pegfilgrastim is a protein produced by biotechnology in bacteria called *E. coli*. The protein belongs to the group of proteins called cytokines and is very similar to a natural protein (Granulocyte-colony stimulating factor=G-CSF) produced by your own body.

2. Before using the medicine

Do not use the medicine if:

- You are hypersensitive (allergic) to pegfilgrastim, filgrastim, *E. coli* derived proteins, or to any of the other ingredients this medicine contains (see section 6).

Special warnings regarding the use of the medicine

Before the treatment with Fulphila, tell your doctor, pharmacist or nurse if:

- if you experience an allergic reaction, including weakness, drop in blood pressure, difficulty breathing, swelling of the face (anaphylaxis), redness and flushing, skin rash, and areas of the skin that itch.
- if you experience coughing, fever, and difficulty breathing. This can be a sign of an Acute Respiratory Distress Syndrome (ARDS).
- if you have any or a combination of the following side effects:
Swelling or puffiness that might be associated with urinating less frequently, difficulty breathing, abdominal swelling and feeling of fullness, and a general feeling of tiredness. These could be symptoms of a condition called "Capillary Leak Syndrome" which causes blood to leak from the small blood vessels into your body. See section 4 "Side effects".
- if you have left upper abdominal pain or pain at the tip of your shoulder. This may be a sign of a problem with your spleen (an enlarged spleen – splenomegaly).
- if you have recently had a serious lung infection (pneumonia), fluid in the lungs (pulmonary edema), inflammation of the lungs (interstitial lung disease) or an abnormal chest x-ray (lung infiltration).
- if you are aware of any altered blood cell counts, (e.g., increase in white blood cells or anemia) or decreased blood platelet counts, which reduces the ability of your blood to clot (thrombocytopenia). Your doctor may want to monitor you more closely.
- if you have sickle cell anemia. Your doctor may monitor your condition more closely.
- if you are a patient with breast cancer or lung cancer, **Fulphila** in combination with chemotherapy and/or radiation therapy may increase your risk of a precancerous blood condition called myelodysplastic syndrome (MDS) or a blood cancer called acute myeloid leukaemia (AML). Symptoms may include tiredness, fever, and easy bruising or bleeding.
- if you have sudden signs of allergy such as rash, itching or hives on the skin, swelling of the face, lips, tongue or other parts of the body, shortness of breath, wheezing or trouble breathing, these could be signs of a severe allergic reaction.
- if you have symptoms of inflammation of the aorta (the large blood vessel which transports blood from the heart to the body), this has been reported rarely in cancer patients and healthy donors. The symptoms can include fever, abdominal pain, weakness, back pain, and an increase in inflammatory markers. Tell your doctor if you experience these symptoms.

Your doctor will check your blood and urine regularly as **Fulphila** can harm the tiny filters inside your kidneys (glomerulonephritis).

Severe skin reactions (Stevens–Johnson syndrome) have been reported with the use of Pegfilgrastim. Stop using **Fulphila** and seek medical attention immediately if you notice any of the symptoms described in section 4 "Side effects".

You should talk to your doctor about your risks of developing cancers of the blood. If you develop or are likely to develop cancers of the blood, do not use the medicine **Fulphila**, unless instructed by your doctor.

Loss of response to Pegfilgrastim

If you no longer respond or maintain the response to Pegfilgrastim treatment, your doctor will investigate the reasons why, such as whether you have developed antibodies which neutralize Pegfilgrastim's activity.

Drug interactions

If you are taking, have recently taken or might take other medicines, including non-prescription medicines and nutritional supplements, tell the doctor or pharmacist.

Children and adolescents

There is no data on the safety and efficacy of using **Fulphila** in children and adolescents.

Pregnancy, breastfeeding, and fertility

Consult your doctor or the pharmacist before taking any medicine.

The medicine **Fulphila** has not been tested in pregnant women.

If you are pregnant, think you may be pregnant or are planning to become pregnant, consult your doctor before using this medicine.

You must stop breastfeeding if you use the medicine **Fulphila**, unless the doctor instructs you otherwise.

Driving and using machines

The medicine **Fulphila** has no or negligible effect on the ability to drive or use machines.

Important information about some of the ingredients of the medicine

This medicine contains 30 mg of sorbitol in each pre-filled syringe, which is equivalent to 50 mg/ml.

This medicine contains less than 1 mmol sodium (23 mg) per 6 mg dose, that is to say essentially "sodium-free".

3. How to use the medicine?

Always use the medicine according to the doctor's instructions. Check with the doctor or pharmacist if you are not sure about the dosage and the manner of treatment with the medicine.

The dosage and manner of treatment will be determined by the doctor only.

The usual recommended dosage is one 6 mg subcutaneous injection (injection under your skin) using a pre-filled syringe, and it should be injected at least 24 hours after your last dose of chemotherapy at the end of each chemotherapy treatment cycle.

Do not shake the medicine **Fulphila** vigorously as this may harm its activity.

Do not exceed the recommended dose.

Self-injection of the medicine Fulphila

Your doctor may decide that it would be more convenient for you to inject the medicine **Fulphila** yourself. Your doctor or the nurse will show you how to inject yourself. Do not try to inject yourself if you have not been trained. For further instructions on how to inject yourself with the medicine **Fulphila**, please read carefully the instructions for use leaflet of

Fulphila, which is included in the package.

If you have accidentally injected a higher dosage of Fulphila

If you used more **Fulphila** than necessary, refer to your doctor, pharmacist, or nurse.

If you have taken an overdose or if a child has accidentally swallowed the medicine, proceed immediately to a doctor or a hospital emergency room and bring the package of the medicine with you.

If you forgot to inject the medicine Fulphila

If you forgot a dose of **Fulphila**, you must refer to your doctor to consult on when you should inject the next dose.

Do not take medicines in the dark! Check the label and the dose each time you take a medicine. Wear glasses if you need them.

If you have further questions on the use of this medicine, consult your doctor, pharmacist, or nurse.

4. Side effects

Like any medicine, the use of **Fulphila** may cause side effects in some users. Do not be alarmed when reading the list of side effects. You may not suffer from any of them.

Please tell your doctor immediately if you have one or a combination of the following side effects:

- Swelling or puffiness which may be associated with urinating less frequently, difficulty breathing, abdominal swelling and feeling of fullness, and a general feeling of tiredness. These side effects generally develop in a rapid fashion.

They could be symptoms of an uncommon condition (a side effect that appears in 1-10 out of 1,000 users) called "Capillary Leak Syndrome" which causes blood to leak from the small blood vessels into your body and requires urgent medical attention.

Very common side effects (effects that occur in more than 1 in 10 users):

- Bone pain. Your doctor will tell you what you can take to ease the bone pain.
- Nausea and headaches.

Common side effects (effects that occur in 1-10 out of 100 users):

- Pain at the site of injection.
- General aches and pains in the joints and muscles.
- Some changes may occur in your blood, but they will be detected by routine blood tests. Your white blood cell count may become high for a short period of time. Your platelet count may become low, which may result in bruising.

Uncommon side effects (effects that occur in 1-10 out of 1,000 users):

- Allergic reactions including redness and flushing, skin rash, and raised areas of the skin that itch.
- Serious allergic reactions including anaphylaxis (weakness, drop in blood pressure, difficulty breathing, swelling of the face).
- Increase in spleen size.
- Spleen rupture. Some cases of spleen rupture were fatal. It is important that you contact your doctor immediately if you experience pain in the upper left side of the abdomen or left shoulder pain, as these may be related to a problem in your spleen.
- Breathing problems. If you have a cough, fever, and difficulty breathing, please tell your doctor.
- Cases of Sweet's Syndrome have occurred (plum-colored, painful and raised lesions on the limbs and sometimes the face and neck, accompanied by fever), but other factors may play a role.
- Cutaneous vasculitis (inflammation of the blood vessels in the skin).

- Damage to the tiny filters inside your kidneys (glomerulonephritis).
- Redness at the site of injection.
- Coughing up blood (hemoptysis).
- Blood disorders (myelodysplastic syndrome [MDS] or acute myeloid leukaemia [AML]).

Rare side effects (effects that occur in 1-10 out of 10,000 users):

- Inflammation of the aorta (the large blood vessel which transports blood from the heart to the body). See section 2 "Before using the medicine".
- Bleeding from the lung (pulmonary hemorrhage).
- Stevens-Johnson syndrome, which can appear as reddish target-like or circular patches often with central blisters on the center of the body, skin peeling, ulcers in the mouth, throat, nose, genitals, and eyes; can be preceded by fever and flu-like symptoms. Stop using **Fulphila** if you develop these symptoms and contact your doctor or seek medical attention immediately. See also section 2 "Before using the medicine".

If a side effect appears, if one of the side effects worsens or if you suffer from a side effect which is not mentioned in this leaflet, consult the doctor.

Reporting of side effects:

Side effects can be reported to the Ministry of Health by clicking the link "דיווח על תופעות לוואי עקב טיפול תרופתי" found on the homepage of the Ministry of Health website (www.health.gov.il) directing to the online form for reporting side effects or via the link: <https://sideeffects.health.gov.il>

5. How to store the medicine?

- Avoid poisoning! This medicine and any other medicine must be stored in a closed place out of the reach and sight of children and/or infants to avoid poisoning. Do not induce vomiting unless explicitly instructed to do so by the doctor.
- Do not use the medicine after the expiry date (Exp.) stated on the package. The expiry date refers to the last day of that month.
- **Storage conditions:** Store in a refrigerator (2°C-8°C). Store in the outer carton in order to protect from light. Do not shake.
The medicine **Fulphila** can be taken out of the refrigerator and kept at room temperature for no more than 72 hours. Once a syringe is removed from the refrigerator and has reached room temperature it must be used within 72 hours or disposed of. Do not freeze. The syringe must be disposed of if it was frozen more than once.
Do not use this medicine if you notice it is cloudy or has particles in it.
- The medicine **Fulphila** pre-filled syringe is intended for one-time use only!
- Do not throw away any medicines via wastewater or household waste. Ask your pharmacist how to throw away medicines you no longer use. These measures will help protect the environment.

6. Additional information

In addition to the active ingredient, the medicine also contains:

D-Sorbitol, acetate, polysorbate 20, water for injection, sodium

What the medicine looks like and what the package contains:

The medicine **Fulphila** is a solution for injection in a pre-filled syringe (6 mg/0.6 ml). Each package contains one pre-filled syringe with a needle for injection and a needle cap. The syringe is marketed with a blister wrapping, the syringe is provided with an automatic needle guard.

The solution is clear and colorless.

Manufacturer: Biosimilar Collaborations Ireland Limited, Dublin, Ireland

Revised in November 2024 according to MOH guidelines.

Drug registration number at the national drug registry of the Ministry of Health:

164-12-35791-00

Registration holder: Dexcel Ltd., 1 Dexcel St., Or Akiva 3060000, Israel

Instructions for use leaflet

Fulphila[®], Prefilled syringe 6 mg/0.6 ml (10 mg/ml)

For subcutaneous administration

- Read this entire leaflet carefully before using the medicine.
- Also read the Fulphila patient information leaflet, which is included in the package.

Instructions for use

Guide to parts

Before use:

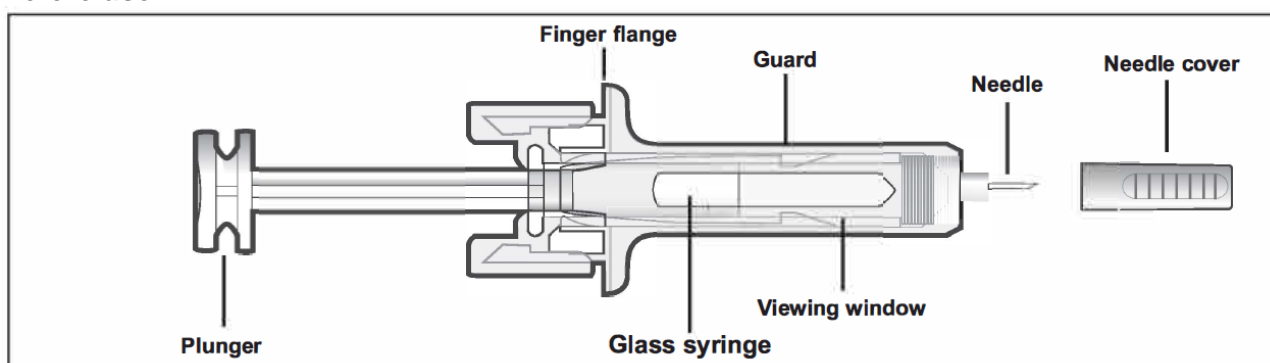

After use:

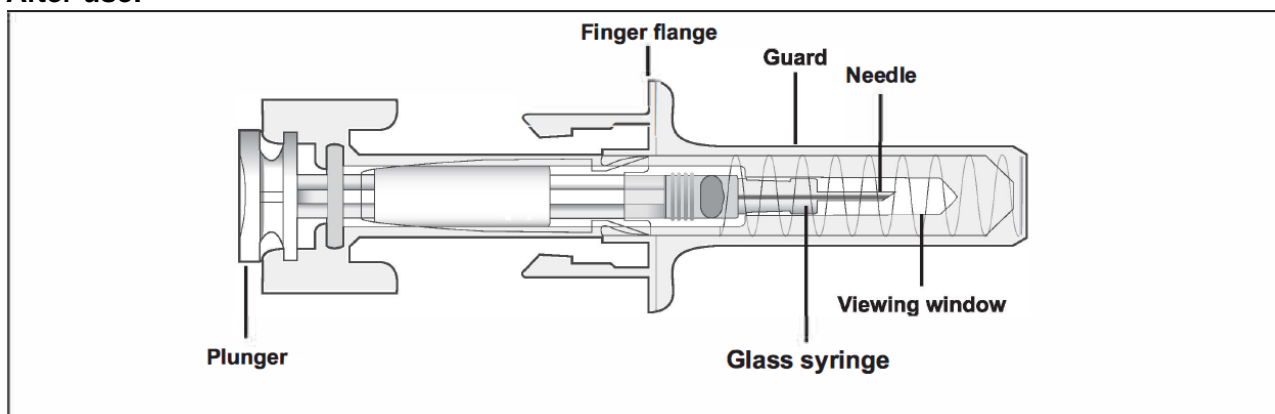

Important

Before using Fulphila pre-filled syringe with automatic needle guard, read the following important information:

- It is important that you do not try to give yourself the injection unless you have received training from your doctor or another healthcare provider.
- **Fulphila** is given as an injection into the tissue just under the skin (subcutaneous injection).
- Do not remove the grey needle cap from the pre-filled syringe until you are ready to inject.
- Do not use the pre-filled syringe if it has been dropped on a hard surface. Use a new pre-filled syringe and call the doctor or another healthcare provider.
- Do not attempt to activate the pre-filled syringe prior to injection.
- Do not attempt to remove the clear syringe safety guard from the pre-filled syringe.

Contact your doctor or another healthcare provider if you have additional questions.

Step 1: Prepare

- A.** Remove the pre-filled syringe tray from the package and gather the supplies needed for your injection: alcohol wipe, a cotton ball or gauze pad, a plaster, and a sharps disposal container (not included).

For a more comfortable injection, leave the pre-filled syringe for about 30 minutes to reach room temperature before injection. Wash your hands thoroughly with soap and water.

Place the new pre-filled syringe and other supplies on a clean and well-lit work surface.

- Do not try to warm the syringe by using a heat source such as hot water or microwave.
- Do not leave the pre-filled syringe exposed to direct sunlight.
- Do not shake the pre-filled syringe.
- Keep the pre-filled syringes out of the reach and sight of children.

- B.** Open the tray, by peeling away the cover. Grab the pre-filled syringe safety guard to remove the pre-filled syringe from the tray.

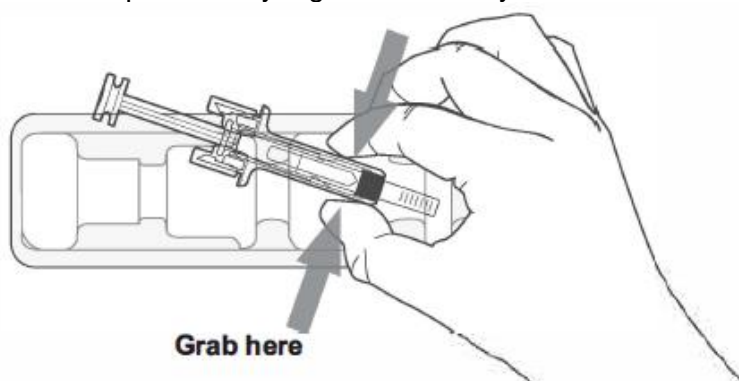

For safety reasons:

- Do not grasp the plunger.
- Do not grasp the grey needle cap.

- C.** Inspect the medicine and pre-filled syringe.

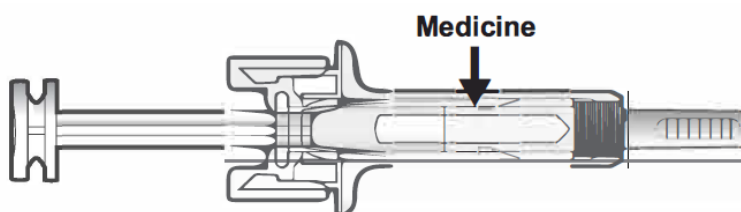

Do not use the pre-filled syringe if:

- The medicine is cloudy or there are particles in it. The liquid must be clear and colorless.
- Any part appears cracked or broken.
- The grey needle cap is missing or not securely attached.
- The expiry date that appears on the label has passed the last day of the month shown.

In all cases, refer to your doctor or another healthcare provider.

Step 2: Get ready

- A.** Wash your hands thoroughly. Prepare and clean your injection site.

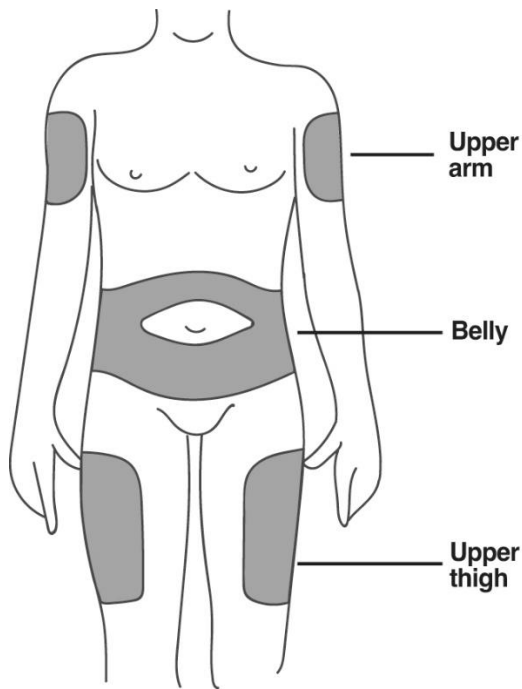

You can inject:

- Upper part of your thigh.
- Belly, except for a 5 cm area around the belly button.
- Outer area of upper arm (only if someone else is giving you the injection).

Clean the injection site with an alcohol wipe. Let your skin dry.

- Do not touch the injection site before injecting.
- Do not inject into areas where the skin is tender, bruised, red, or hard. Avoid injecting into areas with scars or stretch marks.

B. Carefully pull the grey needle cap straight out and away from your body.

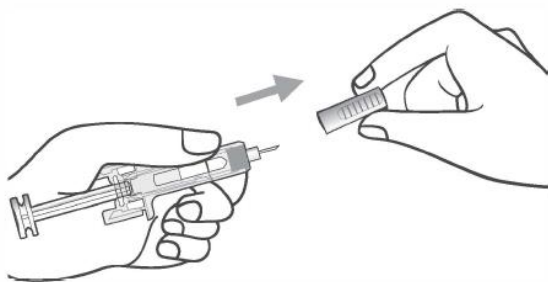

C. Pinch your injection site to create a firm surface.



- It is important to keep the skin pinched when injecting.

Step 3: Inject

- A.** Hold the pinch. **Insert** the needle into the skin.

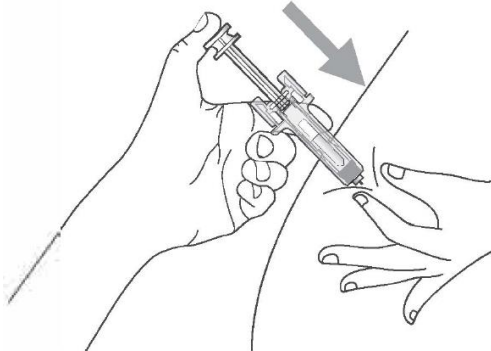

Do not touch the cleaned injection site of the skin.

- B.** **Push** the plunger with slow and constant pressure until you feel or hear a snap sound. Push the plunger all the way down even after the sound.



It is important to push the plunger all the way down after hearing the snap sound in order to deliver the full dose.

- C.** **Release** your thumb. Then **lift** the syringe off the skin.



After releasing the plunger, the syringe safety guard will safely cover the injection needle.

- Do not put the grey needle cap back on the used syringes.

Medical personnel only

The trade name of the product should be clearly recorded in the patient file.

Stage 4: Finish

- A.** Discard the used syringe and additional supplies in a sharps disposal container.

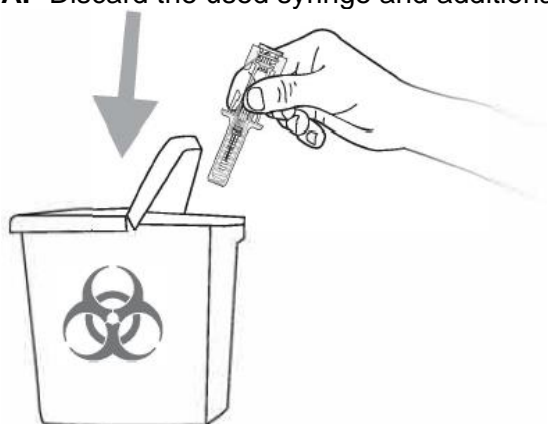

Medicines should be disposed of in accordance with local requirements. Ask your pharmacist how to dispose of medicines that no longer required. These measures will help protect the environment.

Keep the syringes and sharps disposal container out of sight and reach of children.

- Do not reuse the syringe.
- Do not recycle syringes and do not throw them into household waste.

- B.** Examine the injection site.

If you see blood, press a cotton ball or a gauze pad on your injection site. Do not rub the injection site. Apply a plaster if needed.

Manufacturer: Biosimilar Collaborations Ireland Limited, Dublin, Ireland

Revised in November 2024 according to MOH guidelines.

Drug registration number at the national drug registry of the Ministry of Health: 164-12-35791-00

Registration holder: Dexcel Ltd., 1 Dexcel St., Or Akiva 3060000, Israel