

Patient leaflet in accordance with the Pharmacists' Regulations (Preparations) - 1986

This medicine is dispensed with a doctor's prescription only

Cystagon 150 mg

Hard Capsules

Name and quantity of active ingredient:

Cystagon - Each hard capsule contains cysteamine (as cysteamine bitartrate) 150mg

* Inactive ingredients and allergens: see section 6 of this leaflet ('Additional information').

Read the entire leaflet carefully before you start using this medicine. This leaflet contains concise information about this medicine. If you have any further questions, consult your doctor or pharmacist.

This medicine has been prescribed to treat your illness. Do not pass it on to others. It may harm them, even if it seems to you that their illness is similar to yours.

1. What is this medicine intended for?

Cystagon is intended for treating patients who have been diagnosed with nephropathic cystinosis.

The medicine reduces the buildup of cystine in several types of cells (such as white blood cells, muscle and liver cells) in nephropathic cystinosis patients, and when treatment is started early, the medicine postpones development of kidney failure.

Therapeutic group: medicines for treating metabolic diseases.

Cystinosis is a metabolic disease called 'nephropathic cystinosis' which is characterized by an abnormal accumulation of the amino acid cystine in various organs of the body such as the kidney, eye, muscle, pancreas, and brain.

Cystine buildup causes kidney damage and excretion of excess amounts of glucose, proteins and electrolytes. Different organs are affected at different ages.

2. Before using this medicine

X Do not use this medicine if:

- you or your child are sensitive (allergic) to the active substance cysteamine bitartrate, penicillamine, or any of the other ingredients of Cystagon (see section 6 'Additional information').
- you are pregnant, particularly during the first trimester.
- you are breastfeeding.

Special warnings about using this medicine

- When your or your child's metabolic disorder has been confirmed by white blood cells (leucocytes) cystine measurements, the treatment with Cystagon must be started as soon as possible.
- A few cases of skin lesions on the elbows, that look like little hard lumps, have been reported in children treated with high doses of medicines containing cysteamine. These children also had skin striae and bone lesions (fractures and bone deformities) with laxity of joints. Your doctor may, therefore, order routine physical and X-ray examinations to monitor the effects of the medicine. Self-examination of the skin is recommended. If any skin abnormalities appear, or if you suspect any change in the bones, please inform your doctor immediately.
- Cystagon capsules have not been shown to prevent cystine crystals accumulating in the eyes. If you are using cysteamine eye drops for this purpose, do not stop using the eye drops when you start using Cystagon capsules.
- In contrast to phosphocysteamine, another active substance close to cysteamine bitartrate, Cystagon does not contain phosphate. If you are receiving phosphocysteamine and are now being switched to Cystagon capsules (which contain the active substance cysteamine bitartrate), your dose of phosphate supplements, which some patients receive, may need to be adjusted.
- Do not swallow the desiccant canister found in the bottle.

Children: For children under 6 years old, the capsule may be opened and the contents sprinkled on food (such as milk, potatoes or starch-based foods) or mixed in formula. Do not add this medicine to acidic drinks such as orange juice. Consult your doctor for complete directions.

Tests and follow-up

During the course of this treatment, your doctor may refer you to regular blood tests to measure cystine levels in your white blood cells so that the correct dose of Cystagon can be determined. You must have regular blood and urine tests to measure the levels of the important electrolytes in your body; these are necessary to allow your doctor to adjust your dose of supplements.

Other medicines and Cystagon

If you are taking or have recently taken other medicines, including nonprescription medications and dietary supplements, tell your doctor or pharmacist.

Using this medicine and food

Do not add this medicine to acidic drinks such as orange juice.

Pregnancy, breastfeeding, and fertility

Cystagon is not recommended during pregnancy. Consult your doctor if you are planning to have a baby. Do not use Cystagon while breastfeeding.

Driving and using machines

Cystagon may cause drowsiness. When starting treatment, do not engage in potentially hazardous activities until you know how this medicine affects you. Caution children against riding a bicycle, playing near a road, and similar activities.

3. How to use this medicine?

Always use this medicine according to your doctor's instructions. Check with your doctor or pharmacist if you are not sure about your dose or about how to take this medicine.

- Only your doctor will determine your dose and how you should take this medicine. The dose of Cystagon will depend on the patient's weight and age.
- Dose for children up to 12 years old is based on the size of the body (surface area). The standard daily dose is 1.3 grams per square meter of body surface area.
- The standard dose for patients over 12 years old who weigh over 50 kg is 2 grams a day.
- In any case, the standard daily dose should not exceed 1.95 gram per square meter of body surface area.

Do not exceed the recommended dose.

How to take this medicine

Cystagon should be given by mouth and exactly as your doctor directs.

For Cystagon to work properly, you must do the following:

- Follow your doctor's directions exactly. Do not increase or decrease the amount of medicine without your doctor's approval.
- Children under 6 years old: Do not give as a capsule; they may have difficulty swallowing it and may choke. Open the capsule and sprinkle the contents on food (such as milk, potatoes or starch-based food) or mix in formula. Do not add to acidic drinks such as orange juice. Consult the doctor.
- In addition to Cystagon, your treatment, or your child's treatment, can include one or more supplements to replace electrolytes lost through the kidneys. It is important to take these supplements as directed. If you do not take the supplements or if you feel weak or drowsy, call the doctor for instructions.
- You must have regular blood tests to measure the levels of cystine in your white blood cells so that the correct dose of Cystagon can be determined. You must have regular blood and urine tests to measure the levels of important electrolytes in your body; these are necessary to allow your doctor to adjust your dose of supplements.

Do not exceed the recommended dose.

- Take Cystagon 4 times a day, in other words, every 6 hours, preferably just after or with food. It is important to take the dose as close to every 6 hours as possible.
- Do not stop taking this medicine without consulting your doctor.

To easily open and close the Cystagon bottle, please follow the instructions below:
Directions for opening and closing the container

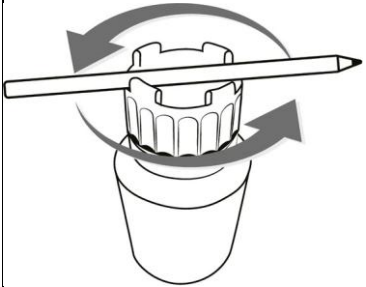
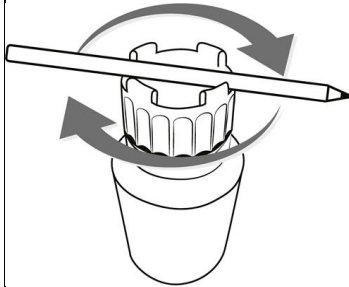
OPEN	CLOSE
	
<p>To Open Place pen or similar object between the raised sections of the lid and turn in the direction shown (anticlockwise)</p>	<p>To Close Place pen or similar object between the raised sections of the lid and turn in the direction shown (clockwise)</p>

If you or your child have taken an overdose, or if a child, who is not the patient, has accidentally swallowed some medicine, immediately see a doctor or go to a hospital emergency room and bring the medicine package with you. You may feel drowsy.

If you forget to take the medicine at the scheduled time, take it as soon as possible. However, if it is within two hours of the next dose, skip the missed dose and take the next dose at the usual time. Do not take a double dose.

Adhere to the treatment as recommended by your doctor. Even if your health improves, do not stop taking this medicine without consulting your doctor.

Do not take medicines in the dark! Check the label and dose every time you take medicine. Wear glasses if you need them.

If you have any further questions about using this medicine, consult your doctor or pharmacist.

4. Side effects

Like with all medicines, using Cystagon may cause side effects in some users. Do not be alarmed by this list of side effects; you may not experience any of them.

Cystagon may cause some people to become drowsy or less alert than usual. Make sure you know how you, or your child, respond to this medicine to prevent dangerous situations.

Very common side effects - may affect more than 1 in 10 users: vomiting, nausea, diarrhea, loss of appetite, fever, sensation of sleep.

Common side effects - may affect 1-10 in 100 users: abdominal pain or discomfort, unpleasant breath and body odor, skin rash, inflammation of the stomach and gut (gastroenteritis), fatigue, headache, encephalopathy (brain disorder), and liver function test abnormalities.

Uncommon side effects - may affect 1-10 in 1000 users: skin striae, skin lesions (little hard lumps on the elbows), joint laxity, leg pain, bone fractures, scoliosis (deviation of the vertebral column), bone deformity and fragility, hair discoloration, severe allergic reaction, somnolence, fits, nervousness, hallucination, decreased white blood cell count, gastrointestinal ulcer that manifests as bleeding in the digestive tract, and effect on the kidneys that manifests as swelling of the extremities and weight gain.

Since some of these side effects are serious, ask your or your child's doctor to explain their warning signs.

If you experience any side effect, if any side effect gets worse, or if you experience a side effect not mentioned in this leaflet, consult your doctor.

You can report side effects to the Ministry of Health by following the link 'Reporting Side Effects of Drug Treatment' on the Ministry of Health home page (www.health.gov.il) which links to an online form for reporting side effects, or by the following link: <https://sideeffects.health.gov.il>

5. How to store the medicine?

- Prevent poisoning! To prevent poisoning, keep this, and all other medicines, in a closed place, out of the reach and sight of children and/or infants. Do not induce vomiting unless explicitly instructed to do so by a doctor.
- Do not use the medicine after the expiry date (exp. date) which is stated on the package.
The expiry date refers to the last day of that month.
- Storage conditions: Store below 25°C. Keep the bottle tightly closed to protect from light and moisture.
- Do not throw away any medicines via wastewater or household waste. Ask your pharmacist how to throw away medicines you no longer use. These measures will help protect the environment.

6. Additional information

- In addition to the active ingredient, this medicine also contains: microcrystalline cellulose, starch pregelatinized, magnesium stearate/sodium lauryl sulfate, croscarmellose sodium, colloidal silicon dioxide.

The capsule shell is composed of gelatin, titanium gelatin, black ink on hard capsules.

- **What the medicine looks like and contents of the pack:**

Cystagon 150 mg pack contains a bottle with 100 white, opaque hard capsules marked CYSTAGON 150 on the body and RECORDATI RARE DISEASES on the cap.

The package contains a desiccant canister.

Registration holder's name and address: Medison Pharma Ltd., 10 Hashiloach Street, Petach Tikva.

Manufacturer's name and address:

Recordati Rare Diseases, Puteaux, France

Revised in January 2025

Registration number of the medicine in the Ministry of Health's National Drug Registry:

Cystagon 150 mg: 152 28 34049

Cystagon 150 mg-PIL-0125-V1