

**PATIENT PACKAGE INSERT IN ACCORDANCE WITH THE
PHARMACISTS' REGULATIONS (PREPARATIONS) – 1986**

The medicine is dispensed with a doctor's prescription only

Name of the medicine, its form and strength

**Simponi[®], Pre-filled syringe/auto-injector
pen, 50 mg in 0.5 ml**

**Simponi[®], Pre-filled syringe/auto-injector
pen, 100 mg in 1.0 ml**

Solution for injection

The active ingredient and its concentration

Golimumab 50 mg/0.5 ml

Inactive ingredients and allergens in the preparation – See section “Important information about some of the ingredients of the medicine” and section 6 “Further Information”.

Read this leaflet carefully in its entirety before using the medicine. This leaflet contains concise information about the medicine. If you have further questions, refer to the doctor or pharmacist.

This medicine has been prescribed for the treatment of your ailment. Do not pass it on to others. It may harm them even if it seems to you that their ailment is similar.

In addition to this leaflet, Simponi is provided with a Patient Information Card. This card contains important safety information you should be aware of and adhere to before starting and during treatment with Simponi. Read the Patient Information Card and the patient leaflet before you start using the preparation. Keep the card for further reading, if necessary.

1. WHAT IS THE MEDICINE INTENDED FOR?

Rheumatoid arthritis:

Simponi, in combination with methotrexate, is indicated for the treatment of moderate to severe, active rheumatoid arthritis in adult patients, when the response to disease-modifying anti-rheumatic drug (DMARD) therapy including methotrexate was inadequate.

Juvenile idiopathic arthritis:**Polyarticular juvenile idiopathic arthritis (pJIA):**

Simponi, in combination with methotrexate, is indicated for the treatment of polyarticular juvenile idiopathic arthritis in children who weigh at least 40 kg, who have responded inadequately to previous therapy with methotrexate.

Simponi 100 mg is not recommended for children under 18 years of age.

Psoriatic arthritis:

Simponi, as a monotherapy or in combination with methotrexate, is indicated for treatment of active and progressive psoriatic arthritis in adult patients, when the response to previous disease-modifying anti-rheumatic drug (DMARD) therapy was inadequate.

Ankylosing spondylitis:

Simponi is indicated for the treatment of severe, active ankylosing spondylitis in adult patients who have responded inadequately to conventional therapy.

Non-radiographic axial spondyloarthritis (nr-Axial SpA):

Simponi is indicated for the treatment of severe, active non-radiographic axial spondyloarthritis in adult patients with objective signs of inflammation as indicated by elevated levels of C-reactive protein (CRP) and/or magnetic resonance imaging (MRI) evidence, who have had an inadequate response to, or were intolerant of, nonsteroidal anti-inflammatory drugs (NSAIDs).

Ulcerative colitis:

Simponi is indicated for treatment of moderate to severe, active ulcerative colitis in adult patients who have had an inadequate response to conventional therapy including corticosteroids and 6-mercaptopurine (6-MP) or azathioprine (AZA), or who are intolerant of or have medical contraindications for such therapies.

Therapeutic group: TNF-blockers.

Simponi contains the active ingredient called golimumab. Simponi belongs to a group of medicines called TNF-blockers.

Simponi works by blocking the action of a protein called TNF- α (tumor necrosis factor alpha). This protein is involved in inflammatory processes of the body, and blocking it can reduce the inflammation in your body.

2. BEFORE USING THE MEDICINE:

Do not use the medicine if:

- You are sensitive (allergic) to the active ingredient golimumab or to any of the other ingredients contained in the medicine. For a list of the other ingredients, see section 6 “Further Information”.
- You have tuberculosis or any other severe infection.
- You suffer from moderate or severe heart failure.

If you are not sure if any of the above conditions apply to you, talk to your doctor, pharmacist or nurse before using Simponi.

Special warnings regarding use of the medicine

Before treatment with Simponi, tell the doctor if you suffer from the following conditions:

Infections

Tell the doctor immediately if you already have any symptoms of infection or if they occur during or after your treatment with Simponi. Symptoms of infection include fever, cough, shortness of breath, flu-like symptoms, diarrhea, sores, dental problems or a burning sensation when urinating.

- You may get infections more easily while using Simponi.
- Infections may progress more rapidly and may be more severe. In addition, some previous infections may recur.

Tuberculosis

Tell your doctor immediately if symptoms of tuberculosis occur during or after the treatment.

Symptoms of tuberculosis include: persistent cough, weight loss, tiredness, fever or night sweats.

- Cases of tuberculosis have been reported in patients treated with Simponi, in rare cases even in patients treated with medicines for tuberculosis. The doctor will check you to see if you have tuberculosis. The doctor will record the test results on your “Patient Information Card”.
- It is very important that you tell your doctor if you have ever suffered from tuberculosis, or if you have been in close contact with someone who has or had tuberculosis.
- If your doctor is concerned that you are at risk for tuberculosis, you may be treated with medicines for tuberculosis before you begin using Simponi.

Hepatitis B virus (HBV)

- Tell your doctor if you are a carrier of the virus or if you suffer, or have suffered in the past, from viral hepatitis B, before treatment with Simponi.
- Tell your doctor if you think you might be at risk of contracting viral hepatitis B.
- Your doctor should test you for the presence of hepatitis B virus.

- Treatment with TNF-blockers such as Simponi may result in reactivation of viral hepatitis B in patients who carry this virus, which may be life-threatening in some cases.

Invasive fungal infections

- If you have lived in or traveled to an area where infections caused by specific types of fungi that can affect the lungs or other parts of the body (called histoplasmosis, coccidioidomycosis, or blastomycosis) are common, tell your doctor immediately. If you do not know whether these fungal infections are common in the area in which you have lived or traveled, ask your doctor.

Cancer and lymphoma

Before you use Simponi, tell your doctor if you have ever been diagnosed with lymphoma (a type of blood cancer) or any other type of cancer.

- If you use Simponi or other TNF-blockers, your risk for developing lymphoma or another cancer may increase.
- Patients suffering from severe rheumatoid arthritis and other inflammatory diseases for a long time may be at higher than average risk of developing lymphoma.
- Cases of different types of cancer, including unusual types, which sometimes resulted in death, have been diagnosed in children and adolescents who received TNF-blocking agents.
- In rare cases, a specific and severe type of lymphoma called hepatosplenic T-cell lymphoma has been observed in patients receiving other TNF-blockers. Most of them were adolescents or young men. This type of cancer usually resulted in death. Almost all of these patients had also received medicines called azathioprine or 6-mercaptopurine. Tell the doctor if you are taking azathioprine or 6-mercaptopurine together with Simponi.
- Patients suffering from severe persistent asthma, chronic obstructive pulmonary disease (COPD), or who are heavy smokers may be at increased risk for cancer when under treatment with Simponi. If you have severe persistent asthma, COPD or are a heavy smoker, you should discuss with your doctor whether treatment with a TNF-blocker is appropriate for you.
- Some patients treated with golimumab developed certain kinds of skin cancer. If you notice changes in the appearance of the skin or growths on the skin during or after treatment, inform your doctor.

Heart failure

Tell your doctor immediately if you experience new symptoms or worsening of existing symptoms of heart failure. Symptoms of heart failure include shortness of breath or swelling of the feet.

- Onset or worsening of heart failure has been reported with use of TNF-blockers, including Simponi. Some of these patients died.
- If you suffer from mild heart failure and you are being treated with Simponi, you must be closely monitored by your doctor.

Nervous system diseases

Tell your doctor immediately if you have ever been diagnosed with or developed symptoms of a demyelinating disease such as multiple sclerosis. Symptoms may include changes in your vision, weakness in your arms or legs, numbness or tingling in any part of your body. Your doctor will decide if you can receive Simponi.

Operations or dental procedures

- Tell your doctor if you are due to undergo any operation or dental procedure.
- Tell the surgeon or dentist performing the procedure that you are being treated with Simponi by showing the “Patient Information Card”.

Autoimmune diseases

Tell your doctor if you develop symptoms of a disease called lupus. The symptoms include persistent rash, fever, joint pain and tiredness.

- On rare occasions, people treated with TNF-blockers have developed lupus.

Blood disease

In some patients, the body may fail to produce enough of the blood cells that help your body fight infections or help you to stop bleeding. If you develop a fever that does not go away, if you bruise or bleed very easily or look very pale, call your doctor immediately. Your doctor may decide to stop treatment.

If you are not sure if any of the above apply to you, talk to your doctor or pharmacist before using Simponi.

Vaccinations

Tell your doctor if you have had, or are due to receive, a vaccination.

- While using Simponi, you should not receive certain vaccinations (live vaccines).
- Certain vaccinations may cause infections. If you received Simponi while you were pregnant, your baby may be at higher risk for getting such an infection for up to approximately six months after the last dose you received during pregnancy. It is important that you tell your baby’s doctors and other healthcare professionals that you used Simponi during pregnancy so they can decide when your baby can be given any vaccine.

Consult your child's doctor about vaccinating the child. If possible, your child should be vaccinated with all the required vaccinations before using Simponi.

Treatment with a therapeutic agent that may cause an infection

Tell your doctor if you have recently received or are scheduled to receive treatment with a therapeutic agent that may cause an infection (such as BCG instillation for the treatment of cancer).

Allergic reaction

Tell your doctor immediately if you develop symptoms of an allergic reaction after using Simponi. Symptoms of an allergic reaction may include swelling of the face, lips, mouth or throat which may cause difficulty in swallowing or breathing, skin rash, hives, swelling of the hands, feet or ankles.

- Some of these reactions may be serious or, rarely, life-threatening.

- Some of these reactions may occur after the first administration of Simponi.

Children and adolescents

Simponi pre-filled syringe/auto-injector pen, 50 mg in 0.5 ml, is not recommended for use in children weighing less than 40 kg with polyarticular juvenile idiopathic arthritis or in children and adolescents under 18 years of age for any other medical condition.

Simponi pre-filled syringe/auto-injector pen, 100 mg in 1.0 ml, is not recommended for use in children and adolescents under 18 years of age.

Drug interactions

If you are taking, or have recently taken, other medicines, including non-prescription medicines and nutritional supplements, tell the doctor or pharmacist, including other medicines for the treatment of rheumatoid arthritis, polyarticular juvenile idiopathic arthritis, psoriatic arthritis and ankylosing spondylitis, non-radiographic axial spondyloarthritis, or ulcerative colitis.

Especially if you are taking:

- Do not use Simponi together with medicines containing the active substance anakinra or abatacept used for the treatment of rheumatic diseases.
- Inform the doctor or pharmacist if you are using additional medicines that affect the immune system.
- Do not receive certain vaccinations (that contain live components) while using Simponi.

If you are not sure if any of the above apply to you, consult the doctor or pharmacist before beginning treatment with Simponi.

Pregnancy, breastfeeding and fertility

Consult the doctor before using Simponi:

- If you are pregnant or are planning to become pregnant while using Simponi. There is limited information regarding the effects of this medicine on pregnant women. If you are being treated with Simponi, you must avoid becoming pregnant by using adequate contraception during treatment and for at least 6 months after the last Simponi injection.

Simponi should be used during pregnancy only if it is clearly necessary for you.

- At least 6 months must elapse from your last treatment with Simponi before you begin breastfeeding.

You must stop breastfeeding if you are due to receive Simponi.

- If you received Simponi during your pregnancy, your baby may be at higher risk for getting an infection. It is important that you tell your baby's doctors and other healthcare professionals that you used Simponi during your pregnancy, before your baby receives any vaccine (for more information see "Vaccinations" section).

If you are pregnant or breastfeeding, think you may be pregnant or are planning to become pregnant, consult the doctor or pharmacist before using this medicine.

Driving and using machines

Simponi has a mild effect on your ability to drive, use tools or operate machines. Dizziness may occur after using Simponi. If this happens, do not drive, use tools or

operate machines.

Important information about some of the ingredients of the medicine

Latex sensitivity

A part of the pre-filled syringe/auto-injector pen, the needle cover, contains latex. Because latex may cause a severe allergic reaction, tell your doctor before using Simponi if you or your caregiver are allergic to latex.

Sorbitol intolerance

Simponi 50 mg contains 20.5 mg sorbitol (E420). Simponi 100 mg contains 41 mg sorbitol (E420). If you have been told by your doctor that you suffer from an intolerance to certain sugars, contact your doctor before using the medicine.

3. HOW SHOULD THE MEDICINE BE USED?

Always use the preparation according to the doctor's or pharmacist's instructions.

Check with the doctor or pharmacist if you are uncertain about the dosage and treatment regimen of the preparation.

The dosage and treatment regimen will be determined by the doctor only.

The recommended dosage is generally:

For rheumatoid arthritis, psoriatic arthritis and axial spondyloarthritis, including ankylosing spondylitis and non-radiographic axial spondyloarthritis:

- The recommended dose is: 50 mg (the contents of one 50 mg pre-filled syringe/auto-injector pen) once a month, on the same date each month.
- Consult your doctor before injecting your fourth dose. The doctor will determine if you should continue Simponi treatment.
- If you weigh more than 100 kg, the dose might be increased to 100 mg (the contents of two 50 mg pre-filled syringes/auto-injector pens or the contents of one 100 mg pre-filled syringe/auto-injector pen) once a month, on the same date each month.

Polyarticular juvenile idiopathic arthritis:

- For patients weighing at least 40 kg, the recommended dose is 50 mg, once a month, on the same date each month.
- Consult the doctor before you receive the fourth dose. The doctor must determine if you should continue Simponi treatment.

Ulcerative colitis:

The table below indicates how you should usually use the medicine.

<u>Treatment initiation</u>	A starting dose of 200 mg (the contents of 4 pre-filled syringes/auto-injector pens of 50 mg or the contents of 2 pre-filled syringes/auto-injector pens of 100 mg) followed by 100 mg (the contents of 2 pre-filled syringes/auto-injector pens of 50 mg or the contents of one pre-filled syringe/auto-injector pen of 100 mg), 2 weeks later.
<u>Maintenance dosage</u>	<p>In patients weighing less than 80 kg: 50 mg (the contents of 1 pre-filled syringe/auto-injector pen of 50 mg) 4 weeks after your last treatment and every 4 weeks thereafter.</p> <p>Your doctor may decide that you will receive 100 mg (the contents of 2 pre-filled syringes/auto-injector pens of 50 mg or the contents of 1 pre-filled syringe/auto-injector pen of 100 mg), depending on the effect Simponi has on you.</p> <p>In patients weighing 80 kg and more: 100 mg (the contents of 2 pre-filled syringes/auto-injector pens of 50 mg or the contents of 1 pre-filled syringe/auto-injector pen of 100 mg) 4 weeks after your last treatment, and every 4 weeks thereafter.</p>

Do not exceed the recommended dose.

Directions for use:

- Simponi is given by injection under the skin (subcutaneously).
- At the start, the doctor or nurse may inject the medicine. However, you and your doctor may decide that you can inject Simponi yourself. In this case, you will receive training on how to inject Simponi yourself.

Talk to the doctor if you have any questions about giving yourself an injection. "Instructions for administration" are detailed at the end of this leaflet.

If you accidentally took a higher dosage (either by injecting a larger dose at one time, or by injecting too frequently), immediately refer to a doctor or proceed to a hospital emergency room and bring the package of the medicine with you, even if it is empty.

If you forgot to take the medicine

If you forgot to take the medicine on your set date, inject the forgotten dose as soon as you remember. Do not inject a double dose to compensate for the missed dose.

When to inject your next dose?

- If **less than two weeks** have passed from the day you were supposed to receive an injection, inject the forgotten dose as soon as you remember and carry on with the treatment according to the original schedule.
- If **more than two weeks** have passed from the day you were supposed to receive an injection, inject the forgotten dose as soon as you remember and consult the doctor or pharmacist about when you need to take the next dose.

If you are not sure what to do, consult the doctor or pharmacist.
Adhere to the treatment regimen as recommended by the doctor.

If you stop taking the medicine

If you are considering discontinuing taking the medicine, consult the doctor or pharmacist before stopping. Even if there is an improvement in your health, do not stop treatment with the medicine without consulting the doctor.

Do not take medicines in the dark! Check the label and the dose each time you take medicine. Wear glasses if you need them.

If you have any further questions regarding use of the medicine, consult the doctor or pharmacist.

4. SIDE EFFECTS

As with any medicine, use of Simponi may cause side effects in some users. Do not be alarmed when reading the list of side effects. You may not suffer from any of them. Some patients may experience serious side effects and may require treatment. The risk of certain side effects is greater with the 100 mg dosage compared with the 50 mg dosage. Side effects may appear up to several months after the last injection.

Refer to the doctor immediately if any of the following serious side effects occur, including:

- **Allergic reactions which can be severe, or rarely, life-threatening (rare).** Symptoms of an allergic reaction can include swelling of the face, lips, mouth or throat which may cause difficulty in swallowing or breathing, skin rash, hives, swelling of the hands, feet or ankles. Some of these symptoms occurred after the first administration of Simponi.
- **Severe infections (including tuberculosis, bacterial infections including severe blood infections and pneumonia, severe fungal infection or other opportunistic infections) (common).** Symptoms of an infection can include fever, tiredness, cough (persistent), shortness of breath, flu-like symptoms, weight loss, night sweats, diarrhea, sores, dental problems or a burning sensation when urinating.
- **Reactivation of hepatitis B virus (HBV) if you are a carrier or if you have had hepatitis B in the past (rare).** The symptoms can include yellowing of the skin and eyes, dark brown-colored urine, right-sided abdominal pain, fever, nausea, vomiting, feeling very tired.
- **A disease of the nervous system such as multiple sclerosis (rare).** Symptoms of nervous system disease can include changes in vision, weakness of the legs or hands, numbness or tingling in any part of the body.
- **Cancer of the lymph nodes (lymphoma) (rare).** Symptoms of lymphoma can include swelling of the lymph nodes, weight loss or fever.
- **Heart failure (rare).** Symptoms of heart failure can include shortness of breath or swelling of the feet.

- **Signs of disturbances in the immune system called:**
 - **Lupus (rare).** Symptoms can include joint pain or a rash on the cheeks or arms that is sensitive to the sun.
 - **Sarcoidosis (rare).** Symptoms can include persistent cough, shortness of breath, chest pain, fever, swelling of the lymph nodes, weight loss, skin rashes and blurred vision.
- **Swelling of small blood vessels (vasculitis) (rare).** Symptoms can include fever, headache, weight loss, night sweats, rash and nerve problems such as numbness and tingling.
- **Skin cancer (uncommon).** Symptoms of skin cancer can include changes in skin appearance or growths on the surface of the skin.
- **Blood disease (common).** Symptoms of blood disease can include a fever that does not go away, bruising or bleeding very easily or paleness.
- **Blood cancer (leukemia) (rare).** Symptoms of leukemia can include fever, feeling tired, frequent infections, easy bruising, and night sweats.

Tell the doctor immediately if you notice any of the symptoms listed above.

The following additional side effects have been observed on use of Simponi:

Very common side effects (may occur in more than 1 user in 10):

- Upper respiratory tract infections, sore throat or hoarseness, runny nose.

Common side effects (may occur in up to 1 user in 10):

- Abnormal liver test results (elevated liver enzymes) found during blood tests done by the doctor
- Feeling dizzy
- Headaches
- Numbness or tingling feeling
- Superficial fungal infections
- Abscesses
- Bacterial infections (such as cellulitis)
- Low red blood cell counts
- Low white blood cell counts
- Positive blood test for lupus
- Allergic reactions
- Indigestion
- Abdominal pain
- Nausea
- Flu
- Bronchitis
- Sinus infection
- Cold sores
- High blood pressure
- Fever
- Asthma, shortness of breath, wheezing

- Stomach and bowel disorders that include inflammation of the stomach lining and colon, which may cause fever
- Pain and ulcers in the mouth
- Injection site reactions (including redness, hardness, pain, bruising, itching, tingling and irritation)
- Hair loss
- Rash and itching of the skin
- Difficulty sleeping
- Depression
- Feeling weak
- Bone fractures
- Chest discomfort

Uncommon side effects (may occur in up to 1 user in 100):

- Infection in the kidney
- Cancer, including skin cancer and non-cancerous growths or lumps, including skin moles
- Skin blisters
- Severe infection throughout the body (sepsis), sometimes including low blood pressure (septic shock)
- Psoriasis (including on the palms of the hands and/or the soles of the feet and/or in the form of skin blisters)
- Low platelet count
- Combined low platelet, red, and white blood cell counts
- Thyroid disorders
- Increase in blood sugar levels
- Increase in blood cholesterol levels
- Balance disorders
- Vision disturbances
- Eye inflammation (conjunctivitis)
- Eye allergy
- Sensation of heart beating irregularly
- Narrowing of the blood vessels in the heart
- Blood clots
- Flushing
- Constipation
- Chronic inflammatory condition of the lungs
- Gastroesophageal acid reflux
- Gallstones
- Liver disorders
- Breast disorders
- Menstrual disorders

Rare side effects (may occur in up to 1 user in 1,000):

- Failure of the bone marrow to produce blood cells
- Severe decrease in the number of white blood cells
- Infection of the joints or the tissue around them
- Impaired healing
- Inflammation of blood vessels in internal organs
- Leukemia
- Melanoma (a type of skin cancer)
- Merkel cell carcinoma (a type of skin cancer)
- Lichenoid reactions (itchy reddish-purple skin rash and/or threadlike white-gray lines on mucous membranes)
- Scaly, peeling skin
- Immune system disorder that could affect the lungs, skin and lymph nodes (most commonly presenting as sarcoidosis)
- Pain and discoloration of the fingers or toes
- Taste disturbances
- Bladder disorders
- Kidney disorders
- Inflammation of the blood vessels in the skin which results in rash

Side effects of unknown frequency (side effects whose frequency has not yet been determined):

- A rare type of blood cancer affecting mostly young people (hepatosplenic T-cell lymphoma)
- Kaposi's sarcoma, a rare type of cancer related to infection with the human herpes virus 8. Kaposi's sarcoma most commonly manifests as purple lesions on the skin
- Worsening of a condition called dermatomyositis (skin and muscle inflammation, seen as a skin rash accompanied by muscle weakness)

If a side effect occurs, if one of the side effects worsens, or if you suffer from a side effect not mentioned in the leaflet, consult with the doctor.

Side effects can be reported to the Ministry of Health by clicking on the link "Report Side Effects of Drug Treatment" found on the Ministry of Health homepage (www.health.gov.il) that directs you to the online form for reporting side effects, or by entering the link:

<https://sideeffects.health.gov.il>

5. HOW SHOULD THE MEDICINE BE STORED?

- Avoid poisoning! This medicine and any other medicine must be kept in a safe place out of the reach and sight of children and/or infants in order to avoid poisoning. Do not induce vomiting unless explicitly instructed to do so by the doctor.
- Do not use the medicine after the expiry date (exp. date) appearing on the package. The expiry date refers to the last day of that month.

Storage conditions:

- Store in a refrigerator (2°C-8°C); do not freeze.
- Keep the pre-filled syringe/auto-injector pen in the original outer carton package in order to protect the medicine from light.
- This medicine can also be stored out of the refrigerator at a temperature of up to 25°C for a single period of up to 30 days, but not beyond the original expiry date printed on the carton. Write the date of removal of preparation from refrigerator on the carton including day/month/year. Do not return this medicine to refrigerator if it has reached room temperature. Discard this medicine if not used within 30 days from the date of removal from the refrigerator or the expiry date printed on the carton, whichever is earlier.
- Do not use the medicine if you notice that the liquid is not clear to light yellow, is cloudy, or contains foreign particles.

6. FURTHER INFORMATION

- In addition to the active ingredient the medicine also contains:
Sorbitol, L-histidine, polysorbate 80 and water for injections.
- The medicine contains sorbitol (E420) (see “**Important information about some of the ingredients of the medicine**”).
- What the medicine looks like and the contents of the package:
Simponi is supplied as a solution in a pre-filled syringe/auto-injector pen 50 mg in 0.5 ml/100 mg in 1.0 ml.
The solution is clear to slightly opalescent (having a pearl-like shine), colorless to light yellow, and may contain a few small translucent or white particles of protein. Do not use Simponi if the solution is discolored, cloudy or you can see foreign particles in it.

Manufacturer: Cilag AG, Hochstrasse 201, CH-8200, Schaffhausen, Switzerland.

Registration Holder: J-C Health Care Ltd., Kibbutz Shefayim 6099000, Israel.

Registration number of the medicine in the National Drug Registry of the Ministry of Health: 147323321300

Instructions for administration – Auto-injector pen

If you would like to self-inject Simponi, you must be trained by a healthcare professional on how to prepare an injection and give it to yourself. If you have not been trained, please contact your doctor, nurse or pharmacist to schedule a training session.

In these instructions:

- 1. Preparing the auto-injector pen for use**
- 2. Choosing and preparing the injection site**
- 3. Injecting the medicine**
- 4. After the injection**

The diagram below (see Fig. 1) shows what the auto-injector pen “SmartJect” looks like. In this leaflet the auto-injector pen “SmartJect” will sometimes be shortened to “auto-injector”.

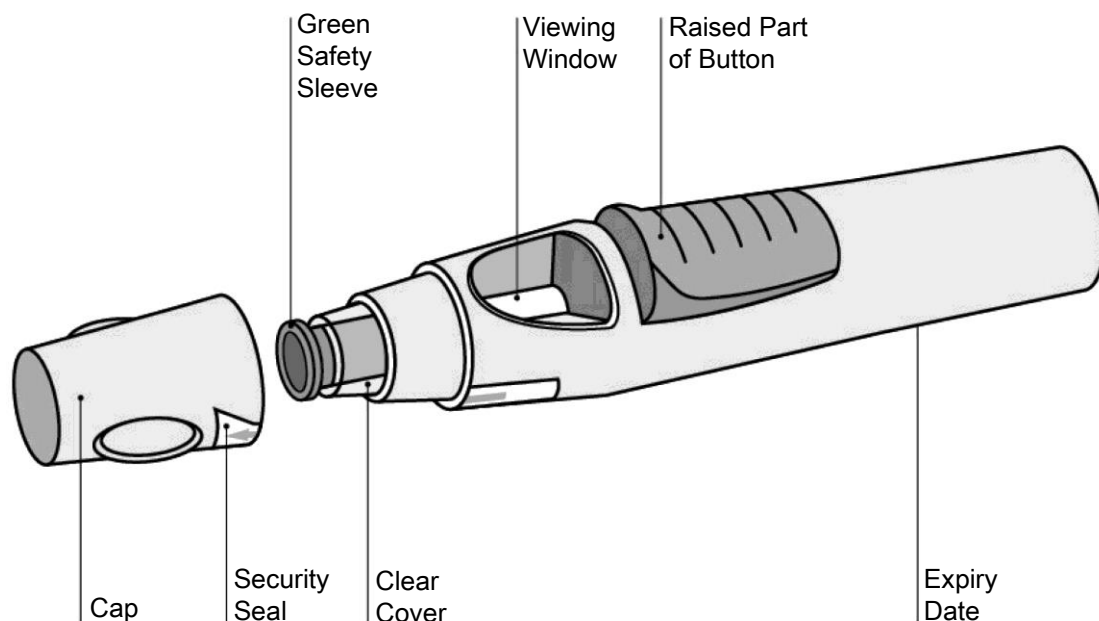

Fig. 1

1. Preparing the auto-injector for use

- Never shake the auto-injector.
- Do not remove the cap from the auto-injector until immediately before the injection.
- Do not put the cap of the auto-injector back on, if removed, to avoid bending the needle.

Check the number of auto-injectors

Check the auto-injectors to ensure that:

- The number and strength of the auto-injectors are correct.
 - If your dosage is 50 mg, you will receive one 50 mg auto-injector.
 - If your dosage is 100 mg, you will receive two 50 mg auto-injectors and will have to give yourself two injections, or you will receive one 100 mg auto-injector.
If you receive two 50 mg auto-injectors, choose two different injection sites (e.g., one injection into the right thigh and the other injection into the left thigh) and inject the injections one after the other.
 - If your dosage is 200 mg, you will receive four 50 mg auto-injectors and will have to give yourself four injections, or you will receive two 100 mg auto-injectors and will have to give yourself two injections.
If you receive four 50 mg auto-injectors, choose four different injection sites and inject the injections one after the other.
If you receive two 100 mg auto-injectors, choose two different injection sites and inject the injections one after the other.

Check the expiry date

- Check the expiry date printed or written on the carton box.
- Check the expiry date (indicated after the letters “EXP”) on the auto-injector.
- Do not use the auto-injector if the expiry date has passed. The expiry date refers to

the last day of that month. Please contact your doctor or pharmacist for assistance.

Check the security seal

- Check the security seal around the cap of the auto-injector.
- Do not use the auto-injector if the seal is broken. Please contact your doctor or pharmacist.

Wait 30 minutes to allow the auto-injector to reach room temperature

- To ensure proper injection, allow the auto-injector to sit at room temperature outside the box for 30 minutes, out of the reach of children.
- Do not warm the auto-injector in any other way (for example, do not warm it in a microwave or in hot water).
- Do not remove the auto-injector's cap while allowing it to reach room temperature.

Prepare the rest of your required equipment

While you are waiting, you can prepare the rest of your required equipment, including an alcohol swab, a cotton ball or gauze and an appropriate sharps container.

Check the liquid in the auto-injector

- Look through the viewing window to make sure that the liquid in the auto-injector is clear to slightly opalescent (having a pearl-like shine) and colorless to light yellow. The solution may contain a few small translucent or white particles of protein. It may be used.
- You will also notice an air bubble, which is normal.
- Do not use the auto-injector if the liquid is the wrong color, cloudy or contains larger particles. If this happens, talk to your doctor or pharmacist.

2. Choosing and preparing the injection site (see Fig. 2)

- You can inject the medicine into the front middle of the thighs.
- You can inject into the abdomen below the belly button, **except** for approximately the 5 cm area directly beneath the belly button.
- Do not inject into areas where the skin is tender, bruised, red, scaly or hard or has scars or stretch marks.
- If more than one injection is required at the same administration, inject them into different injection sites.

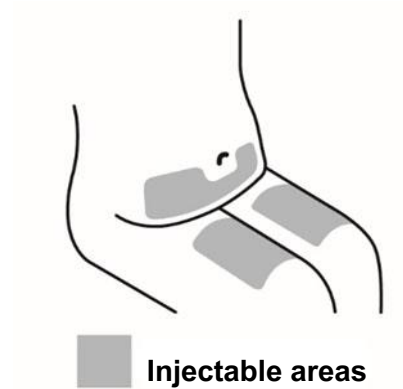

Fig. 2

! DO NOT inject into the arm to avoid failure of the auto-injector and/or unintentional injury.

Wash hands and clean the injection site

- Wash your hands thoroughly with soap and warm water.
- Wipe the injection site with an alcohol swab.
- Allow the skin to dry before injecting. Do not fan or blow on the clean area.
- Do not touch this area again before giving the injection.

3. Injecting the medicine

- Do not remove the cap until you are ready to inject the medicine.
- The medicine should be injected within 5 minutes of removing the cap.

Remove the cap (see Fig. 3)

- When you are ready to inject, twist the cap slightly to break the security seal.
- Pull the cap off and throw it away after the injection.
- Do not put the cap back on because it may damage the needle inside the auto-injector.
- Do not use the auto-injector if it has fallen without the cap in place. If this happens, contact your doctor or pharmacist.

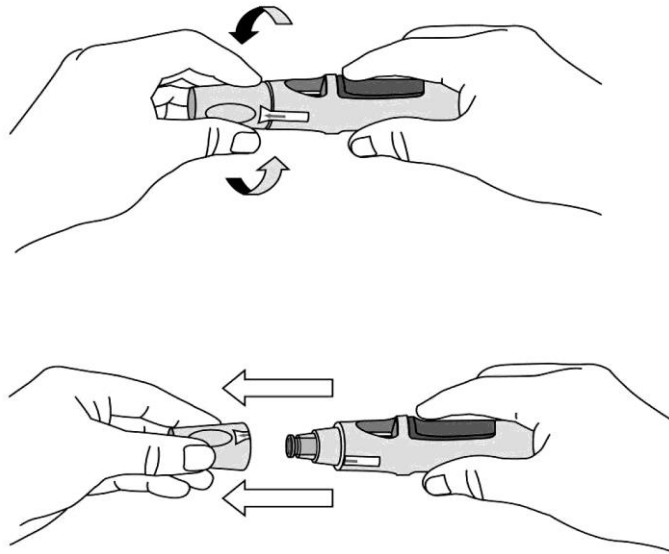

Fig. 3

Press the auto-injector against the skin (see Fig. 4 and 5) without pinching the skin.

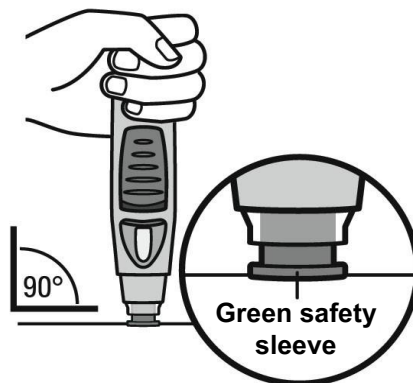

Fig. 4

- Hold the auto-injector comfortably with one hand **above the blue button**.
- Make sure the green safety sleeve is stable and is as flat as possible against your skin. If the auto-injector is not stable during the injection, you risk bending the needle.
- **DO NOT** pinch the skin to avoid unintentional needlestick injury.
- **DO NOT** touch or press the blue button while positioning auto-injector onto your skin.

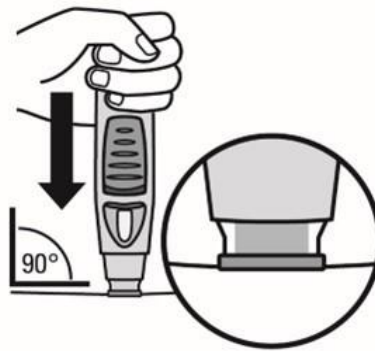

Fig. 5

- Press the open end of the auto-injector against your skin at a 90 degree angle. Apply enough pressure to slide the green safety sleeve up and to maintain it inside the clear cover. Only the wider portion of the green safety sleeve remains outside of the clear cover.
- **DO NOT** press the blue button until after the safety sleeve slides into the clear cover. Pushing the blue button before the safety sleeve is depressed can lead to auto-injector failure.
- Inject without pinching the skin.

* **Press the button to inject (see Fig. 6 and 7)**

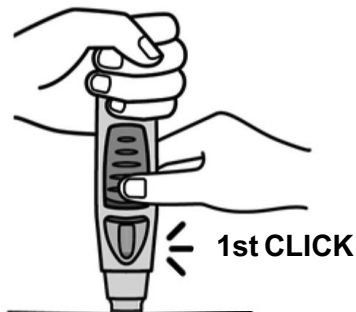

Fig. 6

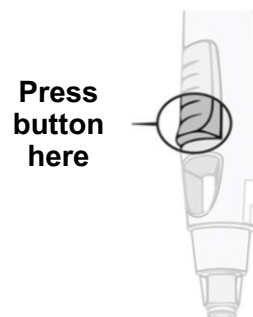

Fig. 7

- **Continue to press the auto-injector against your skin. Use your other hand to press on the raised part of the blue button** to start your injection. Do not press the button unless the auto-injector is **pressed against your skin** and the safety sleeve slides into the clear cover.
- Once the button is pressed, it will remain pressed in so that you do not need to keep applying pressure on it.
- If the button seems hard to depress, don't press the button harder. Let go of the button, lift the auto-injector and start again. Ensure no pressure is on the button until the green safety sleeve is fully depressed against the skin, then press the raised part of the button.

- **You will hear a loud “click” – do not be alarmed.** The first “click” means that the needle has been inserted and the injection has started. You may or may not feel a needle prick.

Do not lift the auto-injector away from your skin yet. If you pull the auto-injector away from your skin, you may not get the full dose of the medicine.

Continue to press until the second “click” (see Fig. 8), it usually takes about 3 to 6 seconds, but may take up to 15 seconds for you to hear the second “click” sound.

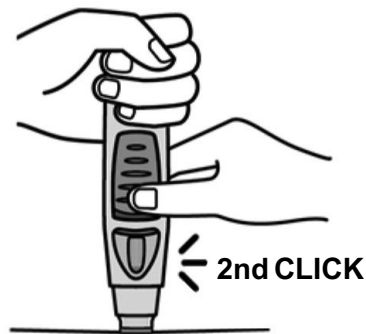

Fig. 8

- **Continue to hold the auto-injector down against your skin until you hear a second “click”, indicating that the injection has finished and the needle has gone back into the auto-injector.**
- Lift the auto-injector from the injection site.
- Note: If you do not hear the second “click”, wait 15 seconds from the time you first press the button and then lift the auto-injector from the injection site.

4. After the injection

Use a cotton ball or gauze

- There may be a small amount of blood or liquid at the injection site. This is normal.
- You can press a cotton ball or gauze over the injection site and hold for 10 seconds.
- If necessary, you may cover the injection site with a small adhesive bandage.
- Do not rub your skin.

Check the viewing window – a yellow indicator confirms a proper injection (see Fig. 9)

- The yellow indicator is connected to the plunger of the auto-injector pen. If the yellow indicator is not visible in the viewing window, the plunger did not advance properly and the injection was not delivered.
- The yellow indicator will fill about half of the viewing window. This is normal.
- Talk to your doctor or pharmacist if the yellow indicator is not visible in the viewing

window or if you suspect that you did not receive the full dose. Do not inject an additional dose without consulting the doctor.

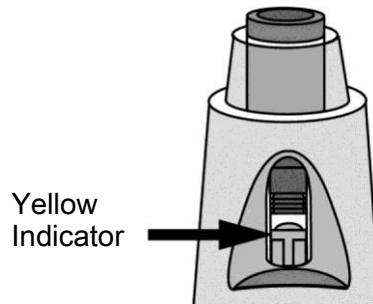

Fig. 9

Throw the auto-injector away

- Discard your auto-injector in an appropriate sharps container, according to the instructions you received from your doctor or nurse.

If you feel that something has gone wrong with the injection or if you are not sure, talk to your doctor or pharmacist.

Instructions for administration – Pre-filled syringe

If you would like to self-inject Simponi, you must be trained by a healthcare professional how to prepare an injection and give it to yourself. If you have not been trained, please contact your doctor, nurse or pharmacist to schedule a training session.

In these instructions:

- 1. Preparing the pre-filled syringe for use**
- 2. Choosing and preparing the injection site**
- 3. Injecting the medicine**
- 4. After the injection**

The diagram below (see Fig. 10) describes what the pre-filled syringe looks like. In this leaflet, “pre-filled syringe” may sometimes be shortened to “syringe”.

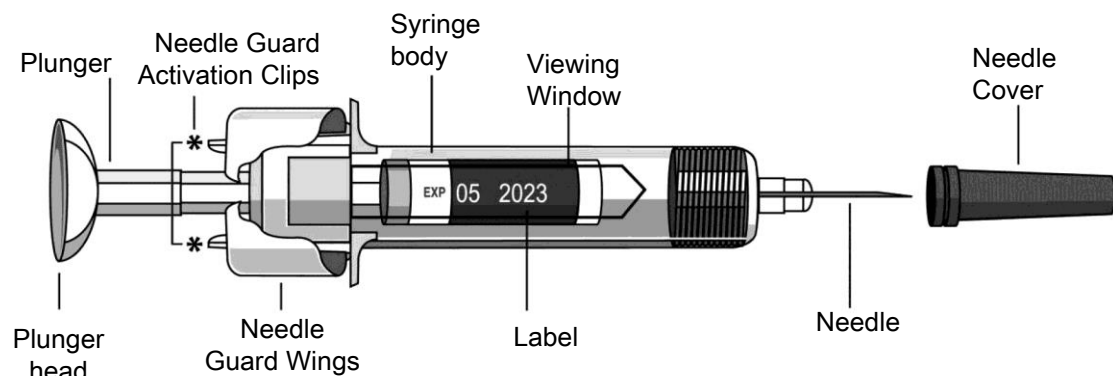

Fig. 10

1. Preparing the syringe for use

Hold the syringe by the body of the syringe

- Do not hold by the plunger head, the plunger, the needle guard wings, or the needle cover.
- Never pull back on the plunger.
- Never shake the syringe.
- Do not remove the cover from the syringe needle until instructed to do so.
- Do not touch the needle guard activation clips (indicated by asterisks * in Fig. 10), to prevent prematurely covering the needle with the needle guard.

Check the number of syringes

Check the syringes to ensure that:

- The number and strength of the syringes are correct.
 - If your dosage is 50 mg, you will receive one 50 mg syringe.
 - If your dosage is 100 mg, you will receive two 50 mg syringes and will have to give yourself two injections, or you will receive one 100 mg syringe.
If you receive two 50 mg syringes, choose two different injection sites (e.g., one injection into the right thigh and the other injection into the left thigh) and inject the injections one after the other.
 - If your dosage is 200 mg, you will receive four 50 mg syringes and will have to give yourself four injections, or you will receive two 100 mg syringes and will have to give yourself two injections.
If you receive four 50 mg syringes, choose four different injection sites and inject the injections one after the other.
If you receive two 100 mg syringes, choose two different injection sites and inject the injections one after the other.

Check the expiry date (see Fig. 11)

- Check the expiry date printed or written on the carton box.
- Check the expiry date (indicated after the letters “EXP”) on the label by looking through the viewing window located in the body of the syringe.
- If you cannot see the expiry date through the viewing window, hold the syringe by its body and rotate the needle cover to line up the expiry date with the viewing window.

Do not use the syringe if the expiry date has passed. The expiry date refers to the last day of that month. Please contact your doctor or pharmacist for assistance.

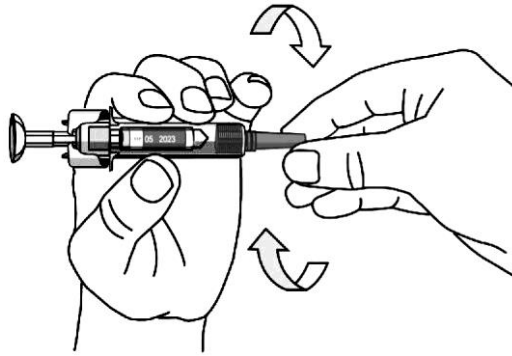

Fig. 11

Wait 30 minutes to allow the syringe to reach room temperature

- To ensure proper injection, allow the syringe to sit at room temperature outside the box for 30 minutes, out of the reach of children.
- Do not warm the syringe in any other way (for example, do not warm it in a microwave or in hot water).
- Do not remove the syringe's needle cover while allowing it to reach room temperature.

Prepare the rest of your required equipment

While you are waiting, you can prepare the rest of your required equipment, including an alcohol swab, a cotton ball or gauze and an appropriate sharps container.

Check the liquid in the syringe

- Hold the syringe by its body with the covered needle pointing downward.
- Look at the liquid through the viewing window of the syringe and make sure that it is clear to slightly opalescent (having a pearl-like shine) and colorless to light yellow. The solution may contain a few small translucent or white particles of protein. The solution can be used.
- If you cannot see the liquid through the viewing window, hold the syringe by its body and rotate the needle cover to line up the liquid with the viewing window (see Fig. 11).

Do not use the syringe if the liquid is the wrong color, cloudy, or contains larger particles. If this happens, talk to your doctor or pharmacist.

2. Choosing and preparing the injection site (see Fig. 12)

- The medicine is usually injected into the front middle of the thighs.
- You can also inject into the lower abdomen below the belly button, **except** for approximately the 5 cm area directly beneath the belly button.
- Do not inject into areas where the skin is tender, bruised, red, scaly or hard or has scars or stretch marks.
- If more than one injection is required at the same administration, inject them into different sites on the body.

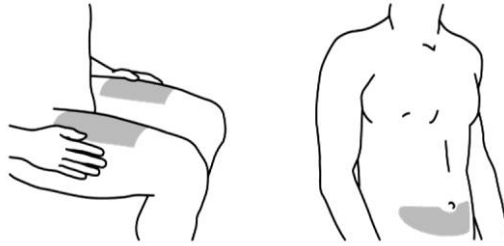

Fig. 12

Injection site selection by caregivers (see Fig. 13)

- If a caregiver is giving you the injection, he/she can also use the outer area of the upper arms.
- In this case too, all sites mentioned can be used, regardless of your body type or size.

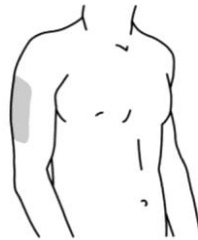

Fig. 13

Preparing the injection site

- Wash your hands thoroughly with soap and warm water.
 - Wipe the injection site with an alcohol swab.
 - Allow the skin to dry before injecting. Do not fan or blow on the clean area.
- Do not touch this area again before giving the injection.

3. Injecting the medicine

The needle cover should not be removed until you are ready to inject the medicine. The medicine should be injected within 5 minutes of removing the needle cover. Do not touch the plunger while removing the needle cover.

Remove the needle cover (see Fig. 14)

- When you are ready to inject, hold the body of the syringe with one hand.
- Pull the needle cover straight off and throw it away. Do not touch the plunger while you do this.
- You may notice an air bubble in the syringe or a drop of liquid at the end of the needle. These are both normal and do not need to be removed.
- Inject the dose immediately after removing the needle cover.

Do not touch the needle or allow it to touch any surface.

Do not use the syringe if it is dropped without the needle cover in place. If this happens, contact your doctor or pharmacist.

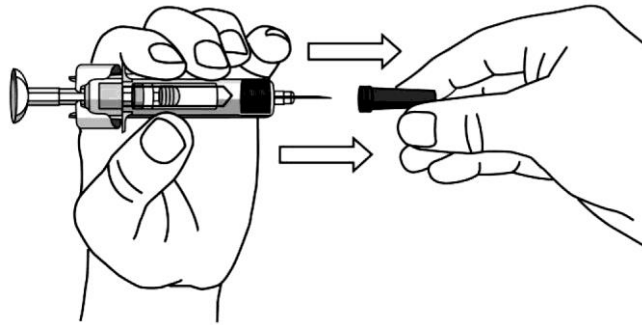

Fig. 14

Position the syringe for injection

- Hold the body of the syringe with one hand between the middle and index fingers and place the thumb on top of the plunger head. Use the other hand to gently pinch the area of skin that you previously cleaned. Hold firmly. Never pull back on the plunger.

Inject the medicine

- Place the needle at approximately a 45-degree angle to the pinched skin. In a single and swift motion, insert the needle through the skin as far as it will go (see Fig. 15).

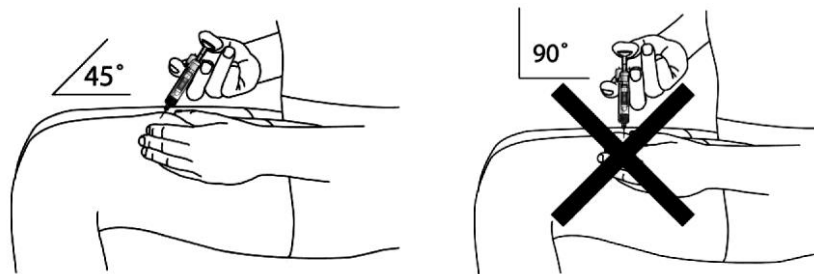

Fig. 15

- Inject all of the medicine by pushing in the plunger until the plunger head is completely between the needle guard wings (see Fig. 16).



Fig. 16

- When the plunger is pushed as far as it will go, continue to keep the pressure on the plunger head, take out the needle and let go of the skin (see Fig. 17).

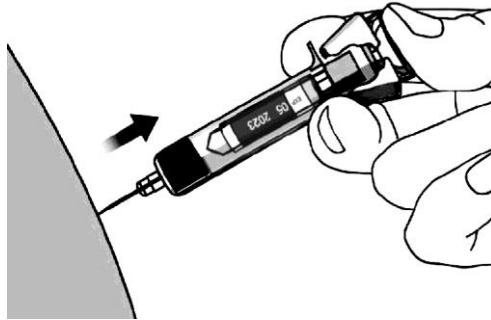

Fig. 17

- Gently take your thumb off the plunger head to allow the empty syringe to move up until the entire needle is covered by the needle guard, as shown in Fig. 18.

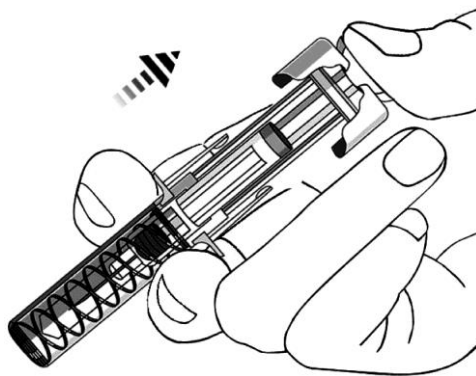

Fig. 18

4. After the injection

Use a cotton ball or gauze

- There may be a small amount of blood or liquid at the injection site. This is normal.
- You can press a cotton ball or gauze over the injection site and hold for 10 seconds.
- If necessary, you may cover the injection site with a small adhesive bandage.

Do not rub your skin.

Throw the syringe away

- Immediately discard the syringe in an appropriate sharps container, according to the instructions received from your doctor or nurse.

Do not attempt to recap the needle.

Never re-use a needle, for your safety and health and for the safety of others.

If you feel that something has gone wrong with the injection or if you are not sure, talk to your doctor or pharmacist.

Revised on July 2024.