

This medicine is dispensed with a doctor's prescription only

## Erelzi 25 Solution for injection in pre-filled syringe

## Erelzi 50 Solution for injection in pre-filled syringe

## Ready to use solution for subcutaneous injection

**Name and quantity of active ingredient:**

Erelzi 25 mg solution for injection: etanercept 25 mg

Erelzi 50 mg solution for injection: etanercept 50 mg

Inactive ingredients and allergens in this medicine: see section 2 under 'Important information about some of the ingredients in Erelzi', and section 6 'Additional information'.

**Read the entire leaflet carefully before you start using this medicine.**

- This leaflet contains concise information about Erelzi. If you have any further questions, consult your doctor or pharmacist.
- This medicine has been prescribed for you. Do not pass it on to others. It may harm them, even if it seems to you that their medical condition is similar to yours.

<p><b>For your attention</b></p> <ul style="list-style-type: none"><li><b>Every time you receive this medicine at the pharmacy, it is important that you confirm that you receive the same medicine that your specialist physician has prescribed for you. If the medicine you are given looks different than the one you usually get, or if the instructions for use have changed, please refer to your pharmacist immediately and verify that you received the correct medicine. Any replacement or change in dosage of a medicine containing etanercept must be performed by the specialist physician only.</b></li> <li><b>Please check that the brand name of the medicine prescribed for you by the specialist physician is identical to the name of the medicine you received from the pharmacist.</b></li> <li><b>In addition to the patient leaflet, there is also a Patient Safety Information Card for Erelzi. This card contains important safety information that you need to be aware of before and during treatment with Erelzi and which you should follow. Read the Patient Safety Information Card and the patient leaflet before you start taking this medicine. Keep the card in case you need to read it again.</b></li> <li><b>Erelzi is a biosimilar medicinal product. For additional information about biosimilar medicinal products, refer to the Ministry of Health's website: <a href="https://www.health.gov.il/UnitsOffice/HD/MTI/Drugs/Registration/Pages/Biosimilars.aspx">https://www.health.gov.il/UnitsOffice/HD/MTI/Drugs/Registration/Pages/Biosimilars.aspx</a></b></li></ul>
---

### 1. What is Erelzi intended for?

Erelzi is intended for the treatment of adults for the following indications:

- Active **rheumatoid arthritis** in adults for whom treatment with disease modifying anti-rheumatic drugs (DMARDs), including methotrexate, has been inadequate; Erelzi can be used in combination with methotrexate in patients who do not respond adequately to treatment with methotrexate alone.
- Active and progressive **psoriatic arthritis** in adults for whom treatment with disease modifying anti-rheumatic drugs (DMARDs) has been inadequate.
- Axial spondyloarthritis**:
  - Active and severe **non-radiographic axial spondyloarthritis** in adults who did not respond adequately to treatment with non-steroidal anti-inflammatory drugs.
  - Severe and active **ankylosing spondylitis** in adults who did not respond adequately to other standard treatment.
- Moderate or severe **plaque psoriasis** in adults who are candidates for systemic therapy or phototherapy.

Erelzi is intended for the treatment of children and adolescents for the following indications:

- Juvenile idiopathic arthritis**:
  - Polyarthritis [rheumatoid factor positive or negative] and extended oligoarthritis in children and adolescents from the age of 2 years who have had an inadequate response to treatment with methotrexate or cannot receive methotrexate.
  - Psoriatic arthritis in children and adolescents from the age of 12 years who have had an inadequate response to treatment with methotrexate or cannot receive methotrexate.
  - Enthesitis-related arthritis in children and adolescents from the age of 12 years who had an inadequate response to treatment or cannot receive any other standard treatment.
- Severe chronic **pediatric plaque psoriasis** in children and adolescents from the age of 6 years who had an inadequate response to or cannot receive systemic therapy or phototherapy.

**Therapeutic group:**

TNF antagonist and selective suppressor of the immune system.

### 2. Before using Erelzi

**Do not use Erelzi if:**

- You or your child are sensitive (allergic) to the active ingredient etanercept or any of the other ingredients of Erelzi (see also section 6).
- You or your child experience an allergic reaction such as chest tightness, wheezing, dizziness or rash, do not continue injecting Erelzi, and refer to your doctor immediately.
- You or your child have or are at risk of developing a serious blood infection called sepsis. **Contact your doctor if you are not sure.**
- You or your child have an infection of any kind. **Contact your doctor if you are not sure.**

**Special warnings about using Erelzi**

- Women of child-bearing potential: use contraception during Erelzi treatment and for three weeks after ending the treatment with Erelzi. See additional information in the 'Pregnancy and breastfeeding' subsection.**
- Contact the doctor immediately** if you/the child experience an allergic reaction such as chest tightness, wheezing, dizziness or rash. In such a case, do not continue injecting Erelzi.
- Tell your doctor** if during treatment with Erelzi you or the child develop a new infection, or are about to have surgery. Your doctor may wish to monitor you or your child during the course of treatment with Erelzi.
- Tell your doctor** if you or the child have a history of recurrent infections or have diabetes or some other condition that may increase the risk of infection.
- Refer to your doctor immediately** if you/your child have recently traveled abroad and develop symptoms of an infection such as fever, chills, or cough. Your doctor may decide to continue to monitor you or the child for the presence of infections after you or the child stop using Erelzi.
- Before starting treatment with Erelzi** your doctor will check for symptoms and signs of tuberculosis, since cases of tuberculosis have been reported in patients treated with Erelzi. The test for tuberculosis may include a thorough medical history, an X-ray, and a Mantoux test.
- Tell your doctor** if you or the child have ever had tuberculosis, or have been in close contact with someone who has ever had tuberculosis.
- Refer to your doctor immediately** if symptoms of tuberculosis (such as persistent cough, weight loss, tiredness, mild fever), or symptoms of any other infection appear during or after completion of treatment with Erelzi.
- Refer to your doctor immediately** if symptoms such as persistent fever, sore throat, tendency to bruising under the skin, bleeding, or paleness occur. Such symptoms may point to the existence of potentially life-threatening blood disorders, which may require discontinuation of Erelzi.
- Tell your doctor** if you or your child have or have ever had hepatitis B (B type viral inflammation of the liver) in the past.
- Before starting treatment with Erelzi**, your doctor will test for the presence of hepatitis B. Treatment with Erelzi may cause reactivation of hepatitis B in patients who have previously been infected with the hepatitis B virus. If the disease recurs, your Erelzi treatment must be stopped.
- Tell your doctor** if you or your child have hepatitis C (type C viral inflammation of the liver). Your doctor may wish to monitor the treatment with Erelzi in case the infection worsens.
- Tell your doctor** if you or the child have multiple sclerosis, optic neuritis (inflammation of the optic nerves) or transverse myelitis (inflammation of the spinal cord) so that your doctor could determine if Erelzi is the right treatment for you.
- Tell your doctor** if you or your child have a history of congestive heart failure, because Erelzi needs to be used with caution in this case.
- Tell your doctor** if you or your child get exposed to chickenpox during treatment with Erelzi. Your doctor will determine if preventive treatment is needed.
- Tell your doctor** if you or your child have a history of alcohol addiction. Do not use Erelzi for the treatment of liver inflammation (hepatitis) related to alcohol abuse.
- Tell your doctor** if you or your child have Wegner's granulomatosis, because Erelzi is not recommended for the treatment of this rare disease.
- Tell your doctor** if you or your child have diabetes and/or are taking medicines to treat diabetes. Your doctor will consider whether there is a need to adjust the dosages of medicines for diabetes during the course of treatment with Erelzi.
- Before you start taking Erelzi, tell your doctor** if you or your child have cancer (such as lymphoma) or if you or your child have a history of cancer. Erelzi may increase the risk of developing cancer.

Patients with severe rheumatoid arthritis, who have had the disease for a long time, may be at a higher risk of developing lymphoma.

Children and adults who are taking Erelzi may have an increased risk of developing lymphoma or any other cancer.

Some children and adolescents who were treated with Erelzi, or other medicines that work in the same way as Erelzi, developed cancer, including unusual types of cancer which in some cases resulted in death.

There are a number of reports of patients receiving etanercept who developed various types of skin cancer. So you must be closely monitored by your doctor and your skin must be checked periodically. **Refer to your doctor immediately** if you notice any changes in your skin or in your child's skin.

**Children and adolescents**

- Erelzi is not indicated for use in children and adolescents who weigh less than 62.5 kg.**
- It is recommended that children be vaccinated before starting treatment with Erelzi. **Tell your doctor** if you or your child are about to receive a vaccine. Some vaccines (such as oral polio vaccine), must not be given during treatment with Erelzi.

**Other medicines and Erelzi**

**If you or your child are taking or have recently taken other medicines, including nonprescription medications and dietary supplements, tell your doctor or pharmacist.**

Inform your doctor if you or your child are taking any medicine that contains the following active ingredients:

- sulphasalazine** used to treat inflammatory bowel disease and rheumatoid arthritis.
- abatacept** used to treat rheumatoid arthritis.
- anakinra** used to treat rheumatoid arthritis.

Do not use medicines that contain the active ingredients **anakinra** or **abatacept** while you are taking Erelzi.

**Using this medicine and food and drink**

You can take Erelzi with or without regard to food or drink.

**Pregnancy and breastfeeding**

Erelzi should only be used during pregnancy if clearly needed. Women of childbearing potential must use contraception during treatment with Erelzi and for three weeks after completing the treatment.

Consult your doctor if you are pregnant, think you may be pregnant, or are planning to have a baby.

If you used Erelzi during pregnancy, your baby may have a higher risk of getting an infection. In addition, one study found more birth defects when the mother had received etanercept during pregnancy, compared with mothers who had not received etanercept or other similar medicines (TNF antagonists), but there was no particular kind of birth defect reported. Another study found no increased risk of birth defects when the mother had received etanercept during pregnancy. Your doctor will help you to decide whether the benefits of treatment outweigh the potential risk to your baby. Talk to your doctor if you want to breastfeed while on Erelzi treatment.

Before the baby receives any vaccine, it is important that you tell the baby's doctors and other healthcare professionals treating the baby that Erelzi was used during pregnancy (for more information see the 'Special warnings about using Erelzi - Children and adolescents' subsection).

**Driving and using machines**

Erelzi is not expected to affect the ability to drive or use machines.

**Important information about some of the ingredients in Erelzi**

Erelzi contains less than 1 mmol sodium (23 mg) per 25 or 50 mg, so it is essentially 'sodium-free'.

### 3. How to use Erelzi

Erelzi is given by injection under the skin (subcutaneous use). Do not swallow this medicine.

Always use this medicine according to your doctor's instructions. Check with your doctor or pharmacist if you are not sure about your dose or about how to take this medicine.

Only your doctor will determine your dose and how you should take this medicine. Depending on your response, your doctor will decide how long you need to take this treatment and whether you need any other treatment.

If there is no improvement after 12 weeks of treatment with Erelzi, your doctor may decide to stop the treatment.

Your doctor will instruct you how to prepare and measure the correct dose.

**Do not exceed the recommended dose.**

**How to use this medicine:**

For detailed instructions on how to prepare and inject Erelzi see the section '**Instructions for use**'.

**To help you remember on which days/s of the week to inject Erelzi, it is advisable to keep a diary.**

**If you inject more Erelzi than you should, consult your doctor immediately.** If a child has accidentally swallowed some medicine, immediately contact a doctor or go to a hospital emergency room and bring the medicine package with you.

**If you forget to inject your dose of Erelzi at the scheduled time**, inject it as soon as you remember (If the next scheduled dose is on the next day, skip the missed dose). Then continue to inject the medicine on the usual days. If you only remember that you missed a dose on the day that the next dose is due, do not inject a double dose to make up for the missed dose.

Adhere to the treatment as recommended by your doctor.

**If you stop using this medicine** your symptoms may return. Consult your doctor or pharmacist about stopping this treatment.

**How can you contribute to the success of your treatment?**

Complete the course of treatment as recommended by your doctor.

Even if your health improves, do not stop taking this medicine without consulting your doctor.

**Do not take medicines in the dark! Check the label and dose every time you take medicine. Wear glasses if you need them.**

**If you have any further questions about using this medicine, consult your doctor or pharmacist.**

### 4. Side effects

Like with all medicines, using Erelzi may cause side effects in some users. Do not be alarmed by this list of side effects; you/your child may not experience any of them.

If you or your child experience any of the following symptoms of **serious allergy, stop taking this medicine and tell your doctor immediately, or get medical assistance:**

- trouble swallowing or breathing
- swelling of the face, throat, hands, or feet
- feeling nervous or anxious, rapid heartbeats, sudden reddening of the skin and/or a warm feeling
- severe rash, severe itching, or severe hives (urticaria): typically manifests as elevated and itchy patches of red or pale skin

**Consult your doctor immediately if you or your child experience any of the following serious symptoms which indicate rare side effects that are sometimes fatal:**

- Signs of **serious infections** such as high fever that may be accompanied by cough, shortness of breath, chills, weakness, or a hot, red, tender, sore area on the skin or joints.
- Signs of **blood disorders**, such as bleeding, bruising, or paleness.
- Signs of **nerve disorders**, such as numbness or tingling, changes in vision, eye pain, or weakness in an arm or leg.
- Signs of **heart failure or worsening heart failure**, such as fatigue or shortness of breath during activity, swelling in the ankles, a feeling of fullness in the neck or abdomen, night-time shortness of breath or coughing, bluish color of the nails or the lips.
- Signs of **cancer**: Cancer may affect any part of the body including the skin and blood, and possible signs will depend on the type and location of the cancer. These signs may include weight loss, fever, swelling (with or without pain), persistent cough, presence of lumps or growths on the skin.
- Signs of **autoimmune reactions** (where antibodies may harm normal tissues in the body) such as pain, itching, weakness, abnormal breathing, having abnormal thinking, sensation, or vision.
- Signs of **lupus or lupus-like syndrome**, such as weight changes, persistent rash, fever, joint or muscle pain, or fatigue
- Signs of **inflammation of the blood vessels** such as pain, fever, redness or warmth of the skin, or itching.

**Additional side effects**

**Very common side effects (may affect more than 1 in 10 people):**

- infections (including colds, sinusitis, bronchitis, urinary tract infections, skin infections)
- injection site reactions (including bleeding, bruising, redness, itching, pain, or swelling). These reactions are common when you start treatment and do not occur as often after the first month of treatment. Some patients developed a reaction after injecting at a site that had been used before
- headache
- Common side effects (may affect up to 1 in 10 people):**
  - allergic reactions
  - fever
  - rash
  - itching
  - antibodies directed against normal tissue

**Uncommon side effects (may affect up to 1 in 100 people):**

- serious infections (including pneumonia, deep-tissue skin infections, joint infections, blood infections, and infections in other areas)
- worsening of congestive heart failure
- low red blood cell count
- low white blood cell count
- low neutrophil (a type of white blood cell) count
- low blood platelet count
- skin cancer that is not melanoma
- localized swelling of the skin (angioedema)
- hives (urticaria) - typically manifests as elevated and itchy patches of red or pale skin
- eye inflammation
- psoriasis (new or worsening)
- inflammation of the blood vessels affecting multiple organs
- elevated liver enzymes in blood tests (in patients also receiving methotrexate treatment, the frequency of elevated liver function blood tests is common)
- abdominal cramps and pain, diarrhea, weight loss or blood in the stool (signs of bowel problems)

**Rare side effects (may affect up to 1 in 1,000 people):**

- serious allergic reactions (including severe localized swelling of the skin and wheezing)
- lymphoma (a type of blood cancer)
- leukemia (cancer affecting the blood and bone marrow)
- melanoma (a type of skin cancer)
- combined low platelet, white, and red blood cell count
- nervous system disorders (with severe muscle weakness and symptoms and signs similar to those of multiple sclerosis or inflammation of the optic nerve or spinal cord)
- tuberculosis
- new onset of congestive heart failure
- seizures
- lupus or lupus-like syndrome (symptoms may include persistent rash, fever, joint pain, and tiredness)
- skin rash which may lead to severe blistering and peeling of the skin
- lichen planus (lichenoid reaction - a reddish-purplish itchy rash or white-gray thread-like lines over a mucous membrane)
- inflammation of the liver caused by the body's immune system (autoimmune hepatitis; in patients also receiving methotrexate treatment, the side effect is uncommon)
- immune disorders that can affect the lungs, skin, and lymph nodes (sarcoidosis)
- inflammation or scarring of the lungs (in patients also receiving methotrexate treatment, the side effect of inflammation or scarring of the lungs is uncommon)
- Damage to the tiny filters inside your kidneys leading to poor kidney function (glomerulonephritis)

**Very rare side effects (may affect up to 1 in 10,000 people):**

- failure of the bone marrow to produce crucial blood cells

**Side effects of unknown frequency:**

- a type of skin cancer called Merkel cell carcinoma
- Kaposi's sarcoma, a rare cancer related to infection with human herpes virus 8. Kaposi's sarcoma most commonly appears as purple lesions on the skin
- excessive activation of white blood cells associated with inflammation (macrophage activation syndrome)
- recurrence of hepatitis B
- worsening of a condition called dermatomyositis (muscle inflammation and weakness with an accompanying skin rash)

**Side effects in children and adolescents**

The side effects and their frequencies seen in children and adolescents are similar to those described above.

**If you experience any side effect, if any side effect gets worse, or if you experience a side effect not mentioned in this leaflet, consult your doctor.**

**Reporting side effects**

You can report side effects to the Ministry of Health by following the link 'Reporting Side Effects of Drug Treatment' on the Ministry of Health home page ([www.health.gov.il](http://www.health.gov.il)) which links to an online form for reporting side effects. You can also use this link: <https://sideeffects.health.gov.il>

### 5. How to store Erelzi

**Prevent poisoning!** To prevent poisoning, keep this and all other medicines in a closed place, out of the reach and sight of children and/or infants. Do not induce vomiting unless explicitly instructed to do so by a doctor.

Do not use Erelzi after the expiry date (exp. date) which is stated on the carton and the syringe. The expiry date refers to the last day of that month.

**Storage conditions**

Store this medicine in a refrigerator (2°C – 8°C). **Do not freeze.** Store in the original package in order to protect from light.

After taking a syringe out of the refrigerator, wait about 15-30 minutes to allow the medicine to reach room temperature. Do not warm the medicine!

Erelzi may be stored outside of the refrigerator at temperatures up to a maximum of 25°C for a single period of up to 4 weeks (and no later than the expiry date); after which, it must not be refrigerated again. Discard this medicine if not used within 4 weeks after removal from the refrigerator.

Inspect the solution before use. The solution should be clear to slightly opalescent, colorless to slightly yellowish, and may contain small white or almost translucent particles of protein. This appearance is normal. Do not use the solution if it is discolored, cloudy, or if particles other than those described above are present. If you are concerned with the appearance of the solution, consult your pharmacist.

Do not throw away any medicines via wastewater or household waste. Ask your pharmacist how to throw away medicines you no longer use. These measures will help protect the environment.

### 6. Additional information

**What does Erelzi contain?**

The active ingredient is etanercept.

Each pre-filled syringe contains 25 mg or 50 mg of etanercept.

In addition to the active ingredient, this medicine also contains: Sodium citrate dihydrate, sucrose, L-lysine HCl, sodium chloride, citric acid anhydrous, sodium hydroxide, hydrochloric acid, water for injection

**What Erelzi looks like and contents of the pack**

Erelzi 25: Each pre-filled syringe contains about 0.5 ml of clear colorless to slightly yellowish solution. Packs contain 1, 2, 4, 8, 12, or 24 pre-filled syringes with a needle guard. Not all pack sizes may be marketed.

Erelzi 50: Each pre-filled syringe contains about 1 ml of clear colorless to slightly yellowish solution. Packs contain 1, 2, 4, 8, 12, or 24 pre-filled syringes with a needle guard. Not all pack sizes may be marketed.

**License holder and importer's name and address:**

Sandoz Pharmaceuticals Israel Ltd., P.O.Box 9015, Tel Aviv, Israel.

**Registration number of the medicine in the Ministry of Health's National Drug Registry:**

Erelzi 25: 163-20-36011-00

Erelzi 50: 163-21-36037-00

Revised in July 2024

## Instructions for using the Erelzi pre-filled syringe:

**Read all of the following instructions before injecting.**

Your doctor or nurse will show you how to self-inject or how to inject your child with Erelzi. Do not try to inject yourself or your child until you are sure you understand how to prepare and inject the dose.

Each pre-filled syringe is packaged in a plastic blister.

Do not mix Erelzi with other medicines.

**Do not use:**

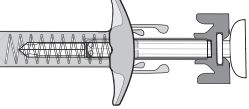

In this configuration the needle guard is ACTIVATED – DO NOT USE the pre-filled syringe

**Ready for use:**

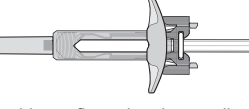

In this configuration the needle guard is NOT ACTIVATED and the pre-filled syringe is ready for use.

**Your Erelzi pre-filled syringe with needle guard and finger flange**

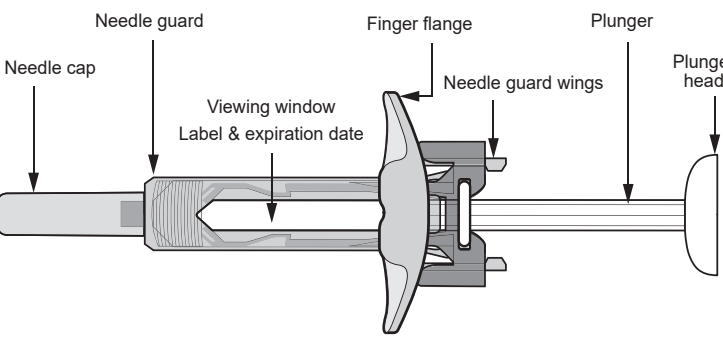

After the medicine has been injected, the needle guard will be activated to cover the needle. This is intended to help protect healthcare professionals, patients who self-inject their medicine, and individuals who assist patients from needle stick injuries.

**What you additionally need for your injection:**

- alcohol wipe
- cotton ball or gauze
- sharps disposal container

**Important safety information**

**Caution: Keep the syringe out of the sight and reach of children.**

- Do not open the outer box until you are ready to use this medicine.
- Do not use this medicine if the seal of the blister is torn, as it may not be safe for you to use.
- Do not shake the syringe.
- Never leave the syringe unsupervised where others might tamper with it.
- The pre-filled syringe has a needle guard that will be activated to cover the needle after the injection is completed. The needle guard will help to prevent needle stick injuries in anyone who helps with or handles the pre-filled syringe. Do not touch the needle guard wings before use. If you touch them, the needle guard may be activated too early.
- Do not remove the needle cap until just before you give the injection.
- Do not re-use the syringe. Dispose of the used syringe immediately after use in a sharps container.
- Do not use the syringe if it has fallen onto a hard surface or fell after the needle cap was removed.**

**Storing the Erelzi pre-filled syringe**

- Store this medicine in its original box to protect it from light. Store in the refrigerator between 2°C to 8°C. Do not freeze this medicine.
- Remember to take the medicine blister out of the refrigerator and allow it to reach room temperature before preparing it for injection (15–30 minutes).
- Do not use the syringe after the expiry date which is stated on the outer box or syringe after "EXP". If the medicine has expired, return the entire pack to the pharmacy.

### The injection site

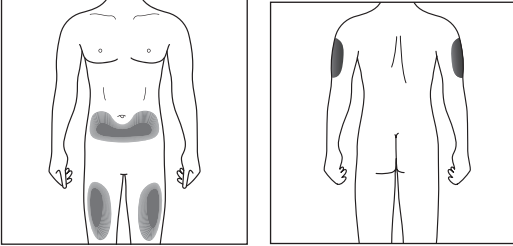

The injection site is the place on the body where you are going to use the pre-filled syringe.

- The recommended site is the front of your thigh. You may also inject in the lower abdomen, **but not** in the area 5 centimeters around the navel (belly button).
- Choose a different site each time you must take this medicine.
- Do not inject into areas where the skin is tender, bruised, red, scaly, or hard. Avoid areas with scars or stretch marks.

If you have psoriasis, do NOT inject directly into any raised, thick, red, or scaly skin patches or lesions ('psoriasis skin lesions').

If a caregiver is giving you the injection, the outer upper arms may also be used.

**Preparing the Erelzi pre-filled syringe**

- Take the blister tray out of the refrigerator and leave it **unopened** for about 15–30 minutes until it reaches room temperature.
- When you are ready to use the syringe, open the blister and wash your hands thoroughly with soap and water.
- Clean the injection site with an alcohol wipe.
- Take the syringe out of the blister.
- Inspect the syringe. The liquid should be clear to slightly opalescent, colorless to slightly yellowish, and may contain small white or almost translucent particles of protein. This appearance is normal for Erelzi. Do not use this medicine if the liquid is cloudy, discolored, or has large lumps, flakes, or particles other than the type described above. Do not use if the syringe is broken or the needle guard is activated. In all these cases, return the entire product pack to the pharmacy.

**How to use the Erelzi pre-filled syringe**

## How to use the Erelzi pre-filled syringe

Carefully remove the needle cap from the syringe. Discard the needle cap. You may see a drop of liquid at the end of the needle. This is normal.



Gently pinch the skin at the injection site and insert the needle as shown in the illustration. Push the needle all the way in to ensure that the medicine can be fully administered.

